



MICROCHIP

PIC16C84

8-bit CMOS EERPOM Microcontroller

High Performance RISC CPU Features:

- Only 35 single word instructions to learn
- All instructions single cycle (400 ns @ 10 MHz) except for program branches which are two-cycle
- Operating speed: DC - 10 MHz clock input
DC - 400 ns instruction cycle
- 14-bit wide instructions
- 8-bit wide data path
- 1K x 14 EEPROM program memory
- 36 x 8 general purpose registers (SRAM)
- 64 x 8 on-chip EEPROM data memory
- 15 special function hardware registers
- Eight-level deep hardware stack
- Direct, indirect and relative addressing modes
- Four interrupt sources:
 - External RB0/INT pin
 - TMR0 timer overflow
 - PORTB<7:4> interrupt on change
 - Data EEPROM write complete
- 1,000,000 data memory EEPROM ERASE/WRITE cycles
- EEPROM Data Retention > 40 years

Peripheral Features:

- 13 I/O pins with individual direction control
- High current sink/source for direct LED drive
 - 25 mA sink max. per pin
 - 20 mA source max. per pin
- TMR0: 8-bit timer/counter with 8-bit programmable prescaler

Special Microcontroller Features:

- Power-on Reset (POR)
- Power-up Timer (PWRT)
- Oscillator Start-up Timer (OST)
- Watchdog Timer (WDT) with its own on-chip RC oscillator for reliable operation
- Code protection
- Power saving SLEEP mode
- Selectable oscillator options
- Serial In-System Programming - via two pins

Pin Diagram

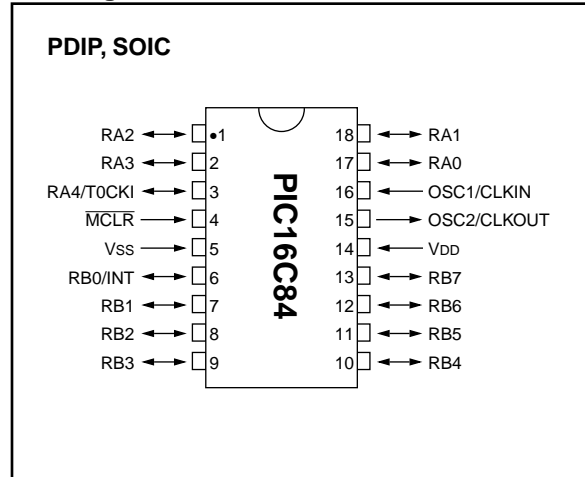

CMOS Technology:

- Low-power, high-speed CMOS EEPROM technology
- Fully static design
- Wide operating voltage range:
 - Commercial: 2.0V to 6.0V
 - Industrial: 2.0V to 6.0V
- Low power consumption:
 - < 2 mA typical @ 5V, 4 MHz
 - 60 μ A typical @ 2V, 32 kHz
 - 26 μ A typical standby current @ 2V

PIC16C84

Table of Contents

1.0 General Description	3
2.0 PIC16C84 Device Varieties	5
3.0 Architectural Overview	7
4.0 Memory Organization.....	11
5.0 I/O Ports.....	19
6.0 Timer0 Module and TMR0 Register.....	25
7.0 Data EEPROM Memory.....	31
8.0 Special Features of the CPU	35
9.0 Instruction Set Summary.....	51
10.0 Development Support	67
11.0 Electrical Characteristics for PIC16C84.....	71
12.0 DC & AC Characteristics Graphs/Tables for PIC16C84	83
13.0 Packaging Information	97
Appendix A: Feature Improvements - From PIC16C5X To PIC16C84	99
Appendix B: Code Compatibility - from PIC16C5X to PIC16C84.....	99
Appendix C: What's New In This Data Sheet.....	100
Appendix D: What's Changed In This Data Sheet	100
Appendix E: Conversion Considerations - PIC16C84 to PIC16F83/F84 And PIC16CR83/CR84.....	101
Index	103
On-Line Support.....	105
PIC16C84 Product Identification System.....	107
Sales and Support.....	107

To Our Valued Customers

We constantly strive to improve the quality of all our products and documentation. We have spent a great deal of time to ensure that these documents are correct. However, we realize that we may have missed a few things. If you find any information that is missing or appears in error, please use the reader response form in the back of this data sheet to inform us. We appreciate your assistance in making this a better document.

1.0 GENERAL DESCRIPTION

The PIC16C84 is a low-cost, high-performance, CMOS, fully-static, 8-bit microcontroller.

All PIC16/17 microcontrollers employ an advanced RISC architecture. PIC16CXX devices have enhanced core features, eight-level deep stack, and multiple internal and external interrupt sources. The separate instruction and data buses of the Harvard architecture allow a 14-bit wide instruction word with a separate 8-bit wide data bus. The two stage instruction pipeline allows all instructions to execute in a single cycle, except for program branches (which require two cycles). A total of 35 instructions (reduced instruction set) are available. Additionally, a large register set is used to achieve a very high performance level.

PIC16CXX microcontrollers typically achieve a 2:1 code compression and up to a 2:1 speed improvement (at 10 MHz) over other 8-bit microcontrollers in their class.

The PIC16C84 has 36 bytes of RAM, 64 bytes of Data EEPROM memory, and 13 I/O pins. A timer/counter is also available.

The PIC16CXX family has special features to reduce external components, thus reducing cost, enhancing system reliability and reducing power consumption. There are four oscillator options, of which the single pin RC oscillator provides a low-cost solution, the LP oscillator minimizes power consumption, XT is a standard crystal, and the HS is for High Speed crystals. The SLEEP (power-down) mode offers power savings. The user can wake the chip from sleep through several external and internal interrupts and resets.

A highly reliable Watchdog Timer with its own on-chip RC oscillator provides protection against software lock-up.

The PIC16C84 EEPROM program memory allows the same device package to be used for prototyping and production. In-circuit reprogrammability allows the code to be updated without the device being removed from the end application. This is useful in the development of many applications where the device may not be easily accessible, but the prototypes may require code updates. This is also useful for remote applications where the code may need to be updated (such as rate information).

Table 1-1 lists the features of the PIC16C84. A simplified block diagram of the PIC16C84 is shown in Figure 3-1.

The PIC16C84 fits perfectly in applications ranging from high speed automotive and appliance motor control to low-power remote sensors, electronic locks, security devices and smart cards. The EEPROM technology makes customization of application programs (transmitter codes, motor speeds, receiver frequencies, security codes, etc.) extremely fast and convenient. The small footprint packages make this microcontroller series perfect for all applications with space limitations. Low cost, low power, high performance, ease of use and I/O flexibility make the PIC16C84 very versatile even in areas where no microcontroller use has been considered before (e.g., timer functions, serial communication, capture and compare, PWM functions and co-processor applications).

The serial in-system programming feature (via two pins) offers flexibility of customizing the product after complete assembly and testing. This feature can be used to serialize a product, store calibration data, or program the device with the current firmware before shipping.

1.1 Family and Upward Compatibility

Those users familiar with the PIC16C5X family of microcontrollers will realize that this is an enhanced version of the PIC16C5X architecture. Please refer to Appendix A for a detailed list of enhancements. Code written for PIC16C5X can be easily ported to the PIC16C84 (Appendix B).

1.2 Development Support

The PIC16CXX family is supported by a full-featured macro assembler, a software simulator, an in-circuit emulator, a low-cost development programmer and a full-featured programmer. A "C" compiler and fuzzy logic support tools are also available.

PIC16C84

TABLE 1-1 PIC16C8X FAMILY OF DEVICES

		PIC16F83	PIC16CR83	PIC16F84	PIC16CR84
Clock	Maximum Frequency of Operation (MHz)	10	10	10	10
	Flash Program Memory	512	—	1K	—
Memory	EEPROM Program Memory	—	—	—	—
	ROM Program Memory	—	512	—	1K
	Data Memory (bytes)	36	36	68	68
Peripherals	Data EEPROM (bytes)	64	64	64	64
	Timer Module(s)	TMR0	TMR0	TMR0	TMR0
	Interrupt Sources	4	4	4	4
Features	I/O Pins	13	13	13	13
	Voltage Range (Volts)	2.0-6.0	2.0-6.0	2.0-6.0	2.0-6.0
	Packages	18-pin DIP, SOIC	18-pin DIP, SOIC	18-pin DIP, SOIC	18-pin DIP, SOIC

All PICmicro™ Family devices have Power-on Reset, selectable Watchdog Timer, selectable code protect and high I/O current capability. All PIC16C8X Family devices use serial programming with clock pin RB6 and data pin RB7.

2.0 PIC16C84 DEVICE VARIETIES

A variety of frequency ranges and packaging options are available. Depending on application and production requirements the proper device option can be selected using the information in this section. When placing orders, please use the "PIC16C84 Product Identification System" at the back of this data sheet to specify the correct part number.

There are two device "types" as indicated in the device number.

1. **C**, as in PIC16**C**84. These devices have EEPROM program memory and operate over the standard voltage range.
2. **LC**, as in PIC16**LC**84. These devices have EEPROM program memory and operate over an extended voltage range.

When discussing memory maps and other architectural features, the use of **C** also implies the **LC** versions.

2.1 Electrically Erasable Devices

These devices are offered in the lower cost plastic package, even though the device can be erased and reprogrammed. This allows the same device to be used for prototype development and pilot programs as well as production.

A further advantage of the electrically erasable version is that they can be erased and reprogrammed in-circuit, or by device programmers, such as Microchip's PICSTART[®] Plus or PRO MATE[®] II programmers.

PIC16C84

NOTES:

3.0 ARCHITECTURAL OVERVIEW

The high performance of the PIC16CXX family can be attributed to a number of architectural features commonly found in RISC microprocessors. To begin with, the PIC16CXX uses a Harvard architecture. This architecture has the program and data accessed from separate memories. So the device has a program memory bus and a data memory bus. This improves bandwidth over traditional von Neumann architecture where program and data are fetched from the same memory (accesses over the same bus). Separating program and data memory further allows instructions to be sized differently than the 8-bit wide data word. PIC16CXX opcodes are 14-bits wide, enabling single word instructions. The full 14-bit wide program memory bus fetches a 14-bit instruction in a single cycle. A two-stage pipeline overlaps fetch and execution of instructions (Example 3-1). Consequently, all instructions execute in a single cycle (400 ns @ 10 MHz) except for program branches.

The PIC16C84 addresses 1K x 14 program memory. All program memory is internal.

PIC16CXX devices can directly or indirectly address its register files or data memory. All special function registers including the program counter are mapped in the data memory. An orthogonal (symmetrical) instruction set that makes it possible to carry out any operation on any register using any addressing mode. This symmetrical nature and lack of 'special optimal situations' make programming with the PIC16CXX simple yet efficient. In addition, the learning curve is reduced significantly.

The PIC16C84 has 36 x 8 SRAM and 64 x 8 EEPROM data memory.

PIC16CXX devices contain an 8-bit ALU and working register. The ALU is a general purpose arithmetic unit. It performs arithmetic and Boolean functions between data in the working register and any register file.

The ALU is 8-bits wide and capable of addition, subtraction, shift and logical operations. Unless otherwise mentioned, arithmetic operations are two's complement in nature. In two-operand instructions, typically one operand is the working register (W register), and the other operand is a file register or an immediate constant. In single operand instructions, the operand is either the W register or a file register.

The W register is an 8-bit working register used for ALU operations. It is not an addressable register.

Depending on the instruction executed, the ALU may affect the values of the Carry (C), Digit Carry (DC), and Zero (Z) bits in the STATUS register. The C and DC bits operate as a borrow and digit borrow out bit, respectively, in subtraction. See the `SUBLW` and `SUBWF` instructions for examples.

A simplified block diagram for the PIC16C84 is shown in Figure 3-1, its corresponding pin description is shown in Table 3-1.

PIC16C84

FIGURE 3-1: PIC16C84 BLOCK DIAGRAM

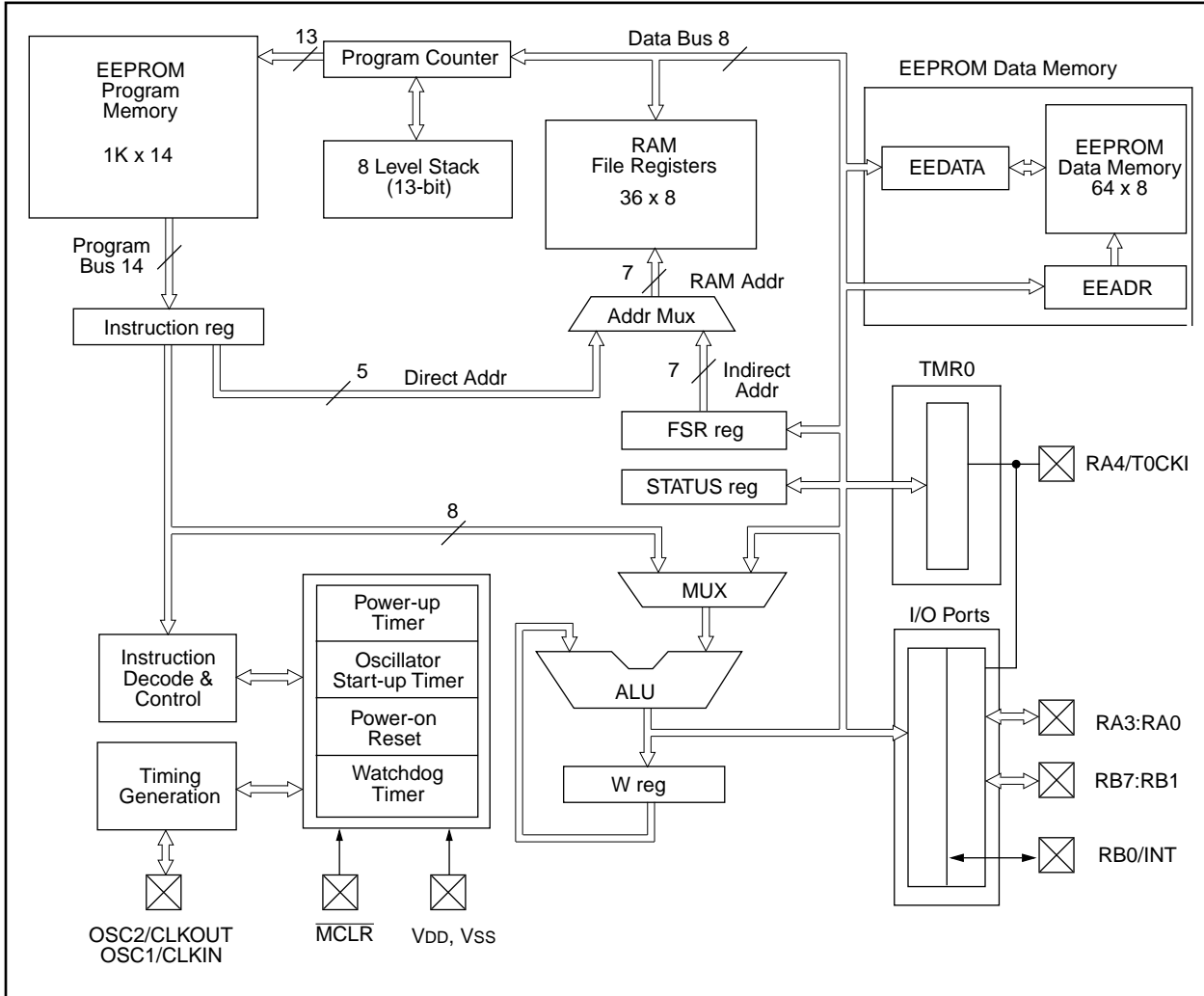

TABLE 3-1 PIC16C8X PINOUT DESCRIPTION

Pin Name	DIP No.	SOIC No.	I/O/P Type	Buffer Type	Description
OSC1/CLKIN	16	16	I	ST/CMOS ⁽¹⁾	Oscillator crystal input/external clock source input.
OSC2/CLKOUT	15	15	O	—	Oscillator crystal output. Connects to crystal or resonator in crystal oscillator mode. In RC mode, OSC2 pin outputs CLKOUT which has 1/4 the frequency of OSC1, and denotes the instruction cycle rate.
MCLR	4	4	I/P	ST	Master clear (reset) input/programming voltage input. This pin is an active low reset to the device.
RA0	17	17	I/O	TTL	PORTA is a bi-directional I/O port. Can also be selected to be the clock input to the TMR0 timer/counter. Output is open drain type.
RA1	18	18	I/O	TTL	
RA2	1	1	I/O	TTL	
RA3	2	2	I/O	TTL	
RA4/T0CKI	3	3	I/O	ST	
RB0/INT	6	6	I/O	TTL	PORTB is a bi-directional I/O port. PORTB can be software programmed for internal weak pull-up on all inputs. RB0/INT can also be selected as an external interrupt pin. Interrupt on change pin. Interrupt on change pin. Interrupt on change pin. Serial programming clock. Interrupt on change pin. Serial programming data.
RB1	7	7	I/O	TTL	
RB2	8	8	I/O	TTL	
RB3	9	9	I/O	TTL	
RB4	10	10	I/O	TTL	
RB5	11	11	I/O	TTL	
RB6	12	12	I/O	TTL/ST ⁽²⁾	
RB7	13	13	I/O	TTL/ST ⁽²⁾	
VSS	5	5	P	—	Ground reference for logic and I/O pins.
VDD	14	14	P	—	Positive supply for logic and I/O pins.

Legend: I = input O = output I/O = Input/Output P = power
 — = Not used TTL = TTL input ST = Schmitt Trigger input

- Note 1:** This buffer is a Schmitt Trigger input when configured in RC oscillator mode and a CMOS input otherwise.
Note 2: This buffer is a Schmitt Trigger input when used in serial programming mode.

PIC16C84

3.1 Clocking Scheme/Instruction Cycle

The clock input (from OSC1) is internally divided by four to generate four non-overlapping quadrature clocks namely Q1, Q2, Q3 and Q4. Internally, the program counter (PC) is incremented every Q1, the instruction is fetched from the program memory and latched into the instruction register in Q4. The instruction is decoded and executed during the following Q1 through Q4. The clocks and instruction execution flow is shown in Figure 3-2.

3.2 Instruction Flow/Pipelining

An "Instruction Cycle" consists of four Q cycles (Q1, Q2, Q3 and Q4). The instruction fetch and execute are pipelined such that fetch takes one instruction cycle while decode and execute takes another instruction cycle. However, due to the pipelining, each instruction effectively executes in one cycle. If an instruction causes the program counter to change (e.g., GOTO) then two cycles are required to complete the instruction (Example 3-1).

A fetch cycle begins with the Program Counter (PC) incrementing in Q1.

In the execution cycle, the fetched instruction is latched into the "Instruction Register" in cycle Q1. This instruction is then decoded and executed during the Q2, Q3, and Q4 cycles. Data memory is read during Q2 (operand read) and written during Q4 (destination write).

FIGURE 3-2: CLOCK/INSTRUCTION CYCLE

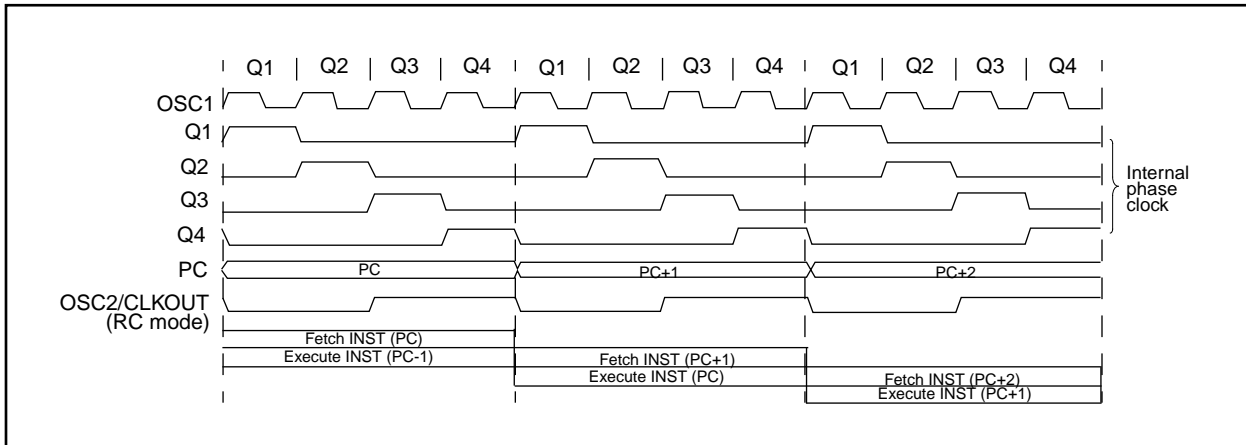

EXAMPLE 3-1: INSTRUCTION PIPELINE FLOW

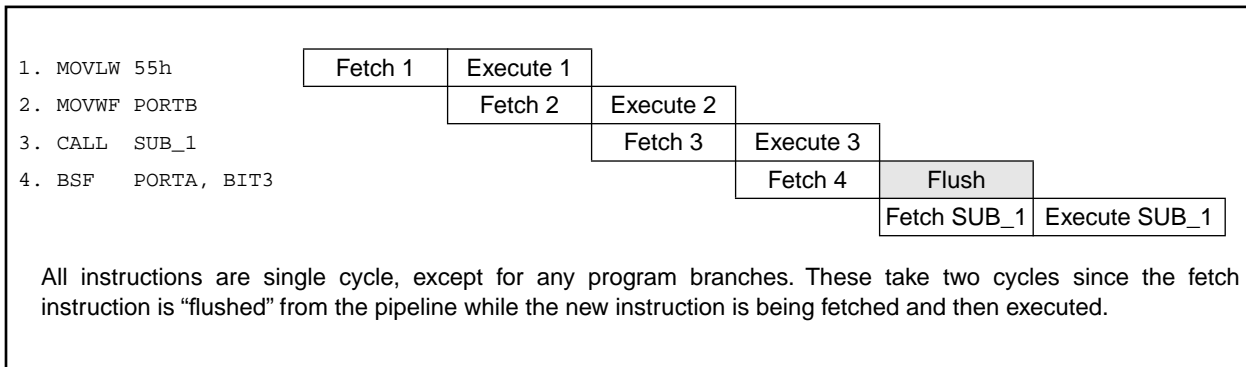

4.0 MEMORY ORGANIZATION

There are two memory blocks in the PIC16C84. These are the program memory and the data memory. Each block has its own bus, so that access to each block can occur during the same oscillator cycle.

The data memory can further be broken down into the general purpose RAM and the Special Function Registers (SFRs). The operation of the SFRs that control the "core" are described here. The SFRs used to control the peripheral modules are described in the section discussing each individual peripheral module.

The data memory area also contains the data EEPROM memory. This memory is not directly mapped into the data memory, but is indirectly mapped. That is an indirect address pointer specifies the address of the data EEPROM memory to read/write. The 64 bytes of data EEPROM memory have the address range 0h-3Fh. More details on the EEPROM memory can be found in Section 7.0.

4.1 Program Memory Organization

The PIC16CXX has a 13-bit program counter capable of addressing an 8K x 14 program memory space. For the PIC16C84, only the first 1K x 14 (0000h-03FFh) are physically implemented (Figure 4-1). Accessing a location above the physically implemented address will cause a wraparound. For example, locations 20h, 420h, 820h, C20h, 1020h, 1420h, 1820h, and 1C20h will be the same instruction.

The reset vector is at 0000h and the interrupt vector is at 0004h.

FIGURE 4-1: PROGRAM MEMORY MAP AND STACK

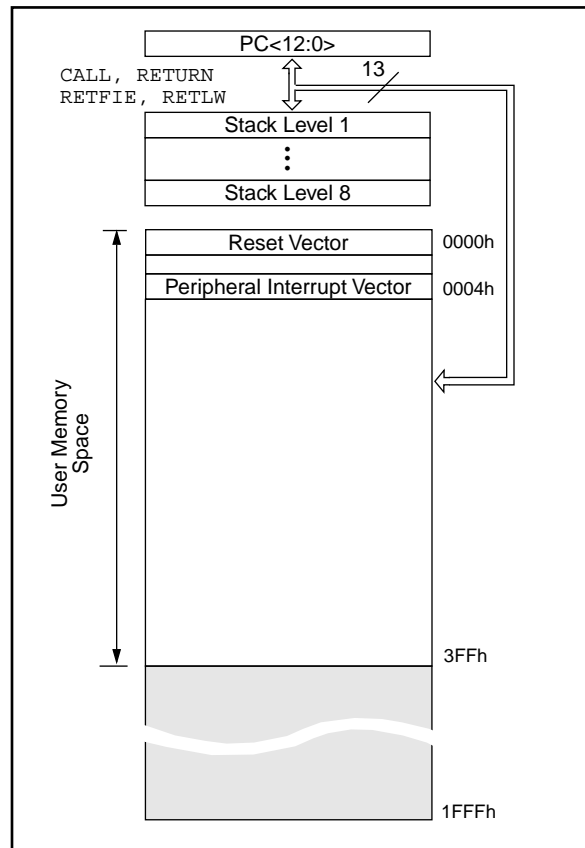

PIC16C84

4.2 Data Memory Organization

The data memory is partitioned into two areas. The first is the Special Function Registers (SFR) area, while the second is the General Purpose Registers (GPR) area. The SFRs control the operation of the device.

Portions of data memory are banked. This is for both the SFR area and the GPR area. The GPR area is banked to allow greater than 116 bytes of general purpose RAM. The banked areas of the SFR are for the registers that control the peripheral functions. Banking requires the use of control bits for bank selection. These control bits are located in the STATUS Register. Figure 4-2 shows the data memory map organization.

Instructions *MOVWF* and *MOVF* can move values from the W register to any location in the register file ("F"), and vice-versa.

The entire data memory can be accessed either directly using the absolute address of each register file or indirectly through the File Select Register (FSR) (Section 4.5). Indirect addressing uses the present value of the RP1:RP0 bits for access into the banked areas of data memory.

Data memory is partitioned into two banks which contain the general purpose registers and the special function registers. Bank 0 is selected by clearing the RP0 bit (STATUS<5>). Setting the RP0 bit selects Bank 1. Each Bank extends up to 7Fh (128 bytes). The first twelve locations of each Bank are reserved for the Special Function Registers. The remainder are General Purpose Registers implemented as static RAM.

4.2.1 GENERAL PURPOSE REGISTER FILE

All devices have some amount of General Purpose Register (GPR) area. Each GPR is 8 bits wide and is accessed either directly or indirectly through the FSR (Section 4.5).

The GPR addresses in bank 1 are mapped to addresses in bank 0. As an example, addressing location 0Ch or 8Ch will access the same GPR.

4.2.2 SPECIAL FUNCTION REGISTERS

The Special Function Registers (Figure 4-2 and Table 4-1) are used by the CPU and Peripheral functions to control the device operation. These registers are static RAM.

The special function registers can be classified into two sets, core and peripheral. Those associated with the core functions are described in this section. Those related to the operation of the peripheral features are described in the section for that specific feature.

FIGURE 4-2: REGISTER FILE MAP

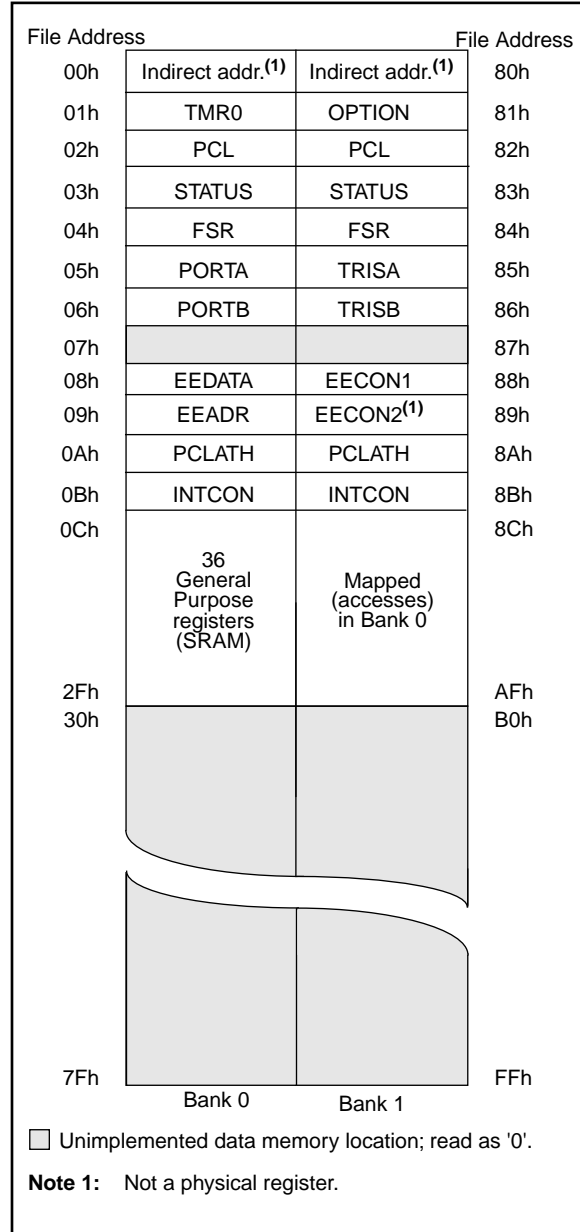

TABLE 4-1 REGISTER FILE SUMMARY

Address	Name	Bit 7	Bit 6	Bit 5	Bit 4	Bit 3	Bit 2	Bit 1	Bit 0	Value on Power-on Reset	Value on all other resets (Note3)		
Bank 0													
00h	INDF	Uses contents of FSR to address data memory (not a physical register)								----	----		
01h	TMR0	8-bit real-time clock/counter								xxxx	xxxx	uuuu	uuuu
02h	PCL	Low order 8 bits of the Program Counter (PC)								0000	0000	0000	0000
03h	STATUS ⁽²⁾	IRP	RP1	RP0	\overline{TO}	\overline{PD}	Z	DC	C	0001	1xxx	000q	quuu
04h	FSR	Indirect data memory address pointer 0								xxxx	xxxx	uuuu	uuuu
05h	PORTA	—	—	—	RA4/ \overline{TOCKI}	RA3	RA2	RA1	RA0	---x	xxxx	---u	uuuu
06h	PORTB	RB7	RB6	RB5	RB4	RB3	RB2	RB1	RB0/INT	xxxx	xxxx	uuuu	uuuu
07h		Unimplemented location, read as '0'								----	----	----	----
08h	EEDATA	EEPROM data register								xxxx	xxxx	uuuu	uuuu
09h	EEADR	EEPROM address register								xxxx	xxxx	uuuu	uuuu
0Ah	PCLATH	—	—	—	Write buffer for upper 5 bits of the PC ⁽¹⁾				---	0000	---	0000	
0Bh	INTCON	GIE	EEIE	TOIE	INTE	RBIE	TOIF	INTF	RBIF	0000	000x	0000	000u
Bank 1													
80h	INDF	Uses contents of FSR to address data memory (not a physical register)								----	----	----	----
81h	OPTION_REG	RBPU	INTEDG	TOCS	TOSE	PSA	PS2	PS1	PS0	1111	1111	1111	1111
82h	PCL	Low order 8 bits of Program Counter (PC)								0000	0000	0000	0000
83h	STATUS ⁽²⁾	IRP	RP1	RP0	\overline{TO}	\overline{PD}	Z	DC	C	0001	1xxx	000q	quuu
84h	FSR	Indirect data memory address pointer 0								xxxx	xxxx	uuuu	uuuu
85h	TRISA	—	—	—	PORTA data direction register				---	1111	---	1111	
86h	TRISB	PORTB data direction register								1111	1111	1111	1111
87h		Unimplemented location, read as '0'								----	----	----	----
88h	EECON1	—	—	—	EEIF	WRERR	WREN	WR	RD	---	x000	---	q000
89h	EECON2	EEPROM control register 2 (not a physical register)								----	----	----	----
0Ah	PCLATH	—	—	—	Write buffer for upper 5 bits of the PC ⁽¹⁾				---	0000	---	0000	
0Bh	INTCON	GIE	EEIE	TOIE	INTE	RBIE	TOIF	INTF	RBIF	0000	000x	0000	000u

Legend: x = unknown, u = unchanged. - = unimplemented read as '0', q = value depends on condition.

Note 1: The upper byte of the program counter is not directly accessible. PCLATH is a slave register for PC<12:8>. The contents of PCLATH can be transferred to the upper byte of the program counter, but the contents of PC<12:8> is never transferred to PCLATH.

2: The \overline{TO} and \overline{PD} status bits in the STATUS register are not affected by a \overline{MCLR} reset.

3: Other (non power-up) resets include: external reset through \overline{MCLR} and the Watchdog Timer Reset.

PIC16C84

4.2.2.1 STATUS REGISTER

The STATUS register contains the arithmetic status of the ALU, the RESET status and the bank select bit for data memory.

As with any register, the STATUS register can be the destination for any instruction. If the STATUS register is the destination for an instruction that affects the Z, DC or C bits, then the write to these three bits is disabled. These bits are set or cleared according to device logic. Furthermore, the \overline{TO} and PD bits are not writable. Therefore, the result of an instruction with the STATUS register as destination may be different than intended.

For example, `CLRF STATUS` will clear the upper-three bits and set the Z bit. This leaves the STATUS register as 000u u1uu (where u = unchanged).

Only the `BCF`, `BSF`, `SWAPF` and `MOVWF` instructions should be used to alter the STATUS register (Table 9-2) because these instructions do not affect any status bit.

Note 1: The IRP and RP1 bits (STATUS<7:6>) are not used by the PIC16C84 and should be programmed as cleared. Use of these bits as general purpose R/W bits is NOT recommended, since this may affect upward compatibility with future products.

Note 2: The C and DC bits operate as a $\overline{\text{borrow}}$ and digit borrow out bit, respectively, in subtraction. See the `SUBLW` and `SUBWF` instructions for examples.

Note 3: When the STATUS register is the destination for an instruction that affects the Z, DC or C bits, then the write to these three bits is disabled. The specified bit(s) will be updated according to device logic

FIGURE 4-3: STATUS REGISTER (ADDRESS 03h, 83h)

R/W-0	R/W-0	R/W-0	R-1	R-1	R/W-x	R/W-x	R/W-x	
IRP	RP1	RP0	\overline{TO}	PD	Z	DC	C	
bit7								bit0

R = Readable bit
W = Writable bit
U = Unimplemented bit, read as '0'
- n = Value at POR reset

bit 7: **IRP:** Register Bank Select bit (used for indirect addressing)
0 = Bank 0, 1 (00h - FFh)
1 = Bank 2, 3 (100h - 1FFh)
The IRP bit is not used by the PIC16C8X. IRP should be maintained clear.

bit 6-5: **RP1:RP0:** Register Bank Select bits (used for direct addressing)
00 = Bank 0 (00h - 7Fh)
01 = Bank 1 (80h - FFh)
10 = Bank 2 (100h - 17Fh)
11 = Bank 3 (180h - 1FFh)
Each bank is 128 bytes. Only bit RP0 is used by the PIC16C8X. RP1 should be maintained clear.

bit 4: **TO:** Time-out bit
1 = After power-up, `CLRWDT` instruction, or `SLEEP` instruction
0 = A WDT time-out occurred

bit 3: **PD:** Power-down bit
1 = After power-up or by the `CLRWDT` instruction
0 = By execution of the `SLEEP` instruction

bit 2: **Z:** Zero bit
1 = The result of an arithmetic or logic operation is zero
0 = The result of an arithmetic or logic operation is not zero

bit 1: **DC:** Digit carry/ $\overline{\text{borrow}}$ bit (for `ADDWF` and `ADDLW` instructions) (For $\overline{\text{borrow}}$ the polarity is reversed)
1 = A carry-out from the 4th low order bit of the result occurred
0 = No carry-out from the 4th low order bit of the result

bit 0: **C:** Carry/ $\overline{\text{borrow}}$ bit (for `ADDWF` and `ADDLW` instructions)
1 = A carry-out from the most significant bit of the result occurred
0 = No carry-out from the most significant bit of the result occurred
Note: For $\overline{\text{borrow}}$ the polarity is reversed. A subtraction is executed by adding the two's complement of the second operand. For rotate (`RRF`, `RLF`) instructions, this bit is loaded with either the high or low order bit of the source register.

4.2.2.2 OPTION_REG REGISTER

The OPTION_REG register is a readable and writable register which contains various control bits to configure the TMR0/WDT prescaler, the external INT interrupt, TMR0, and the weak pull-ups on PORTB.

Note: When the prescaler is assigned to the WDT (PSA = '1'), TMR0 has a 1:1 prescaler assignment.

FIGURE 4-4: OPTION_REG REGISTER (ADDRESS 81h)

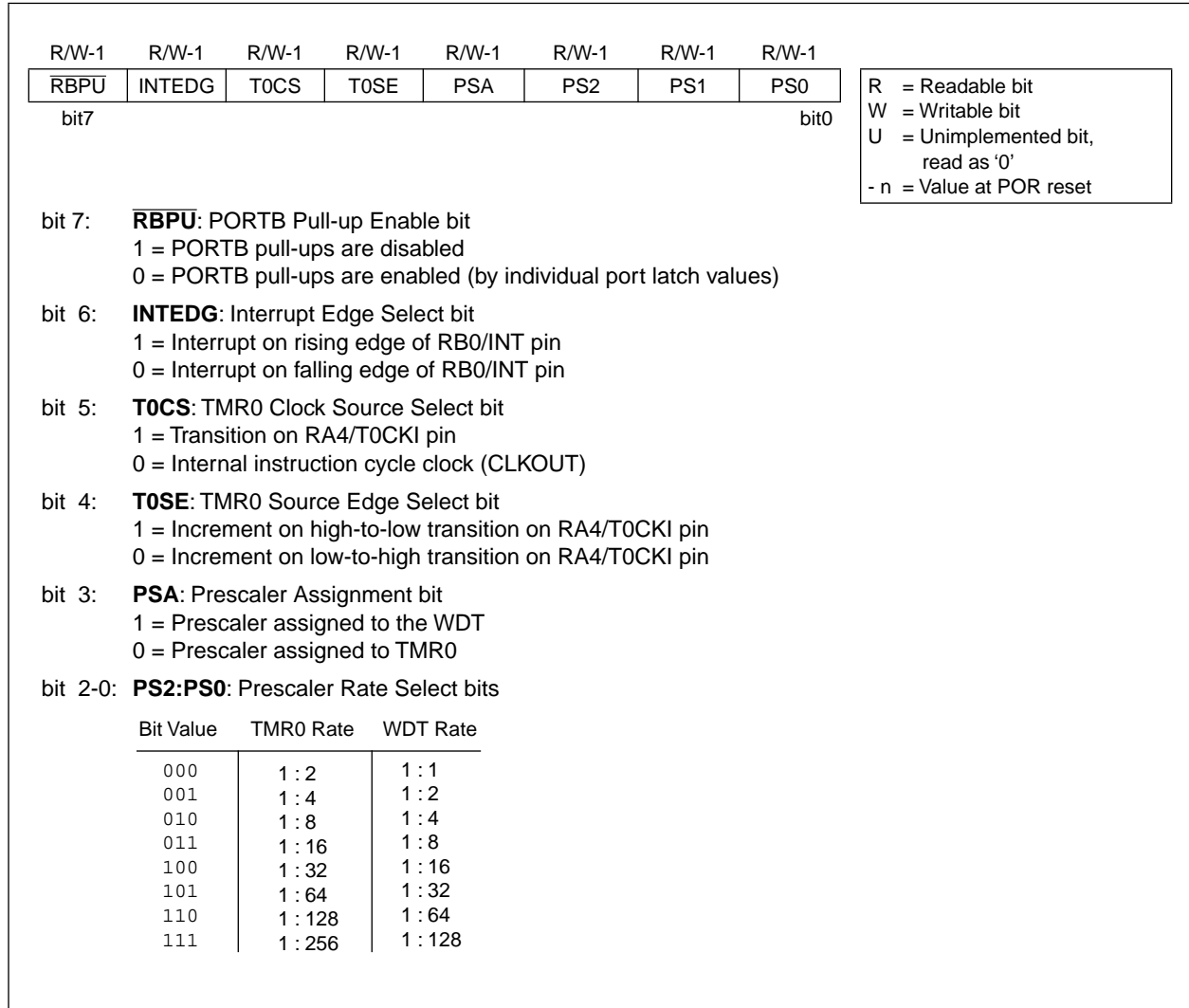

PIC16C84

4.2.2.3 INTCON REGISTER

The INTCON register is a readable and writable register which contains the various enable bits for all interrupt sources.

Note: Interrupt flag bits get set when an interrupt condition occurs regardless of the state of its corresponding enable bit or the global enable bit, GIE (INTCON<7>).

FIGURE 4-5: INTCON REGISTER (ADDRESS 0Bh, 8Bh)

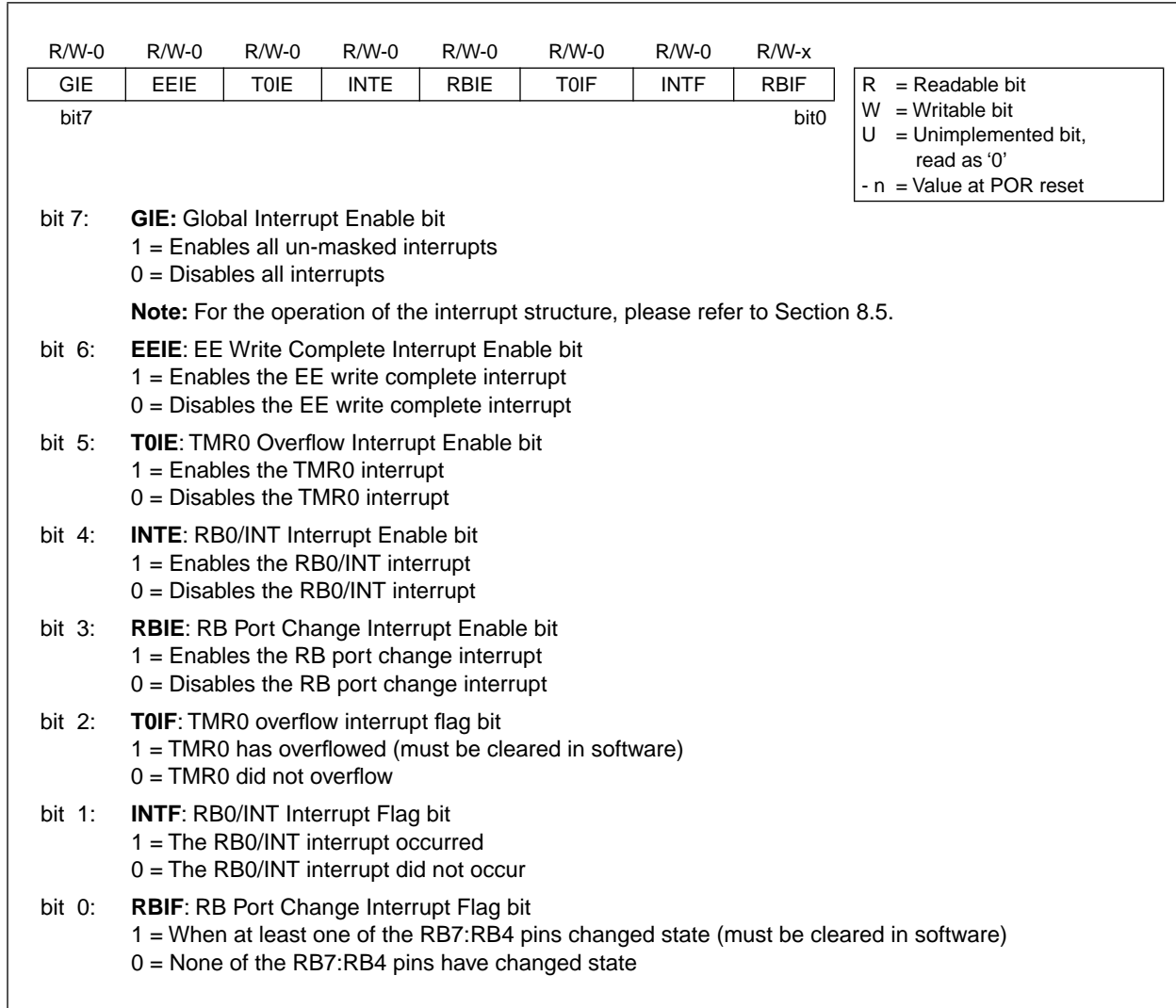

4.3 Program Counter: PCL and PCLATH

The Program Counter (PC) is 13-bits wide. The low byte is the PCL register, which is a readable and writable register. The high byte of the PC (PC<12:8>) is not directly readable nor writable and comes from the PCLATH register. The PCLATH (PC latch high) register is a holding register for PC<12:8>. The contents of PCLATH are transferred to the upper byte of the program counter when the PC is loaded with a new value. This occurs during a `CALL`, `GOTO` or a write to PCL. The high bits of PC are loaded from PCLATH as shown in Figure 4-6.

FIGURE 4-6: LOADING OF PC IN DIFFERENT SITUATIONS

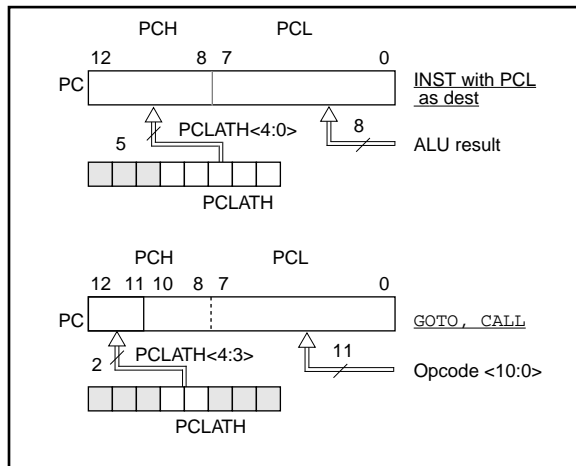

4.3.1 COMPUTED GOTO

A computed GOTO is accomplished by adding an offset to the program counter (`ADDWF PCL`). When doing a table read using a computed GOTO method, care should be exercised if the table location crosses a PCL memory boundary (each 256 word block). Refer to the application note "Implementing a Table Read" (AN556).

4.3.2 PROGRAM MEMORY PAGING

The PIC16C84 has 1K of program memory. The `CALL` and `GOTO` instructions have an 11-bit address range. This 11-bit address range allows a branch within a 2K program memory page size. For future PIC16CXX program memory expansion, there must be another two bits to specify the program memory page. These paging bits come from the PCLATH<4:3> bits (Figure 4-6). When doing a `CALL` or a `GOTO` instruction, the user must ensure that these page bits (PCLATH<4:3>) are programmed to the desired program memory page. If a `CALL` instruction (or interrupt) is executed, the entire 13-bit PC is "pushed" onto the stack (see next section). Therefore, manipulation of the PCLATH<4:3> is not required for the return instructions (which "pops" the PC from the stack).

Note: The PIC16C84 ignores the PCLATH<4:3> bits, which are used for program memory pages 1, 2 and 3 (0800h - 1FFFh). The use of PCLATH<4:3> as general purpose R/W bits is not recommended since this may affect upward compatibility with future products.

4.4 Stack

The PIC16C84 has an 8 deep x 13-bit wide hardware stack (Figure 4-1). The stack space is not part of either program or data space and the stack pointer is not readable or writable.

The entire 13-bit PC is "pushed" onto the stack when a `CALL` instruction is executed or an interrupt is acknowledged. The stack is "popped" in the event of a `RETURN`, `RETLW` or a `RETFIE` instruction execution. PCLATH is not affected by a push or a pop operation.

Note: There are no instruction mnemonics called push or pop. These are actions that occur from the execution of the `CALL`, `RETURN`, `RETLW`, and `RETFIE` instructions, or the vectoring to an interrupt address.

The stack operates as a circular buffer. That is, after the stack has been pushed eight times, the ninth push overwrites the value that was stored from the first push. The tenth push overwrites the second push (and so on).

If the stack is effectively popped nine times, the PC value is the same as the value from the first pop.

Note: There are no status bits to indicate stack overflow or stack underflow conditions.

PIC16C84

4.5 Indirect Addressing; INDF and FSR Registers

The INDF register is not a physical register. Addressing INDF actually addresses the register whose address is contained in the FSR register (FSR is a *pointer*). This is indirect addressing.

EXAMPLE 4-1: INDIRECT ADDRESSING

- Register file 05 contains the value 10h
- Register file 06 contains the value 0Ah
- Load the value 05 into the FSR register
- A read of the INDF register will return the value of 10h
- Increment the value of the FSR register by one (FSR = 06)
- A read of the INDF register now will return the value of 0Ah.

Reading INDF itself indirectly (FSR = 0) will produce 00h. Writing to the INDF register indirectly results in a no-operation (although STATUS bits may be affected).

A simple program to clear RAM locations 20h-2Fh using indirect addressing is shown in Example 4-2.

EXAMPLE 4-2: HOW TO CLEAR RAM USING INDIRECT ADDRESSING

```

movlw 0x20 ;initialize pointer
movwf FSR ; to RAM
NEXT  clrf  INDF ;clear INDF register
      incf  FSR ;inc pointer
      btfss FSR,4 ;all done?
      goto NEXT ;NO, clear next

CONTINUE
      :      ;YES, continue
    
```

An effective 9-bit address is obtained by concatenating the 8-bit FSR register and the IRP bit (STATUS<7>), as shown in Figure 4-7. However, IRP is not used in the PIC16C84.

FIGURE 4-7: DIRECT/INDIRECT ADDRESSING

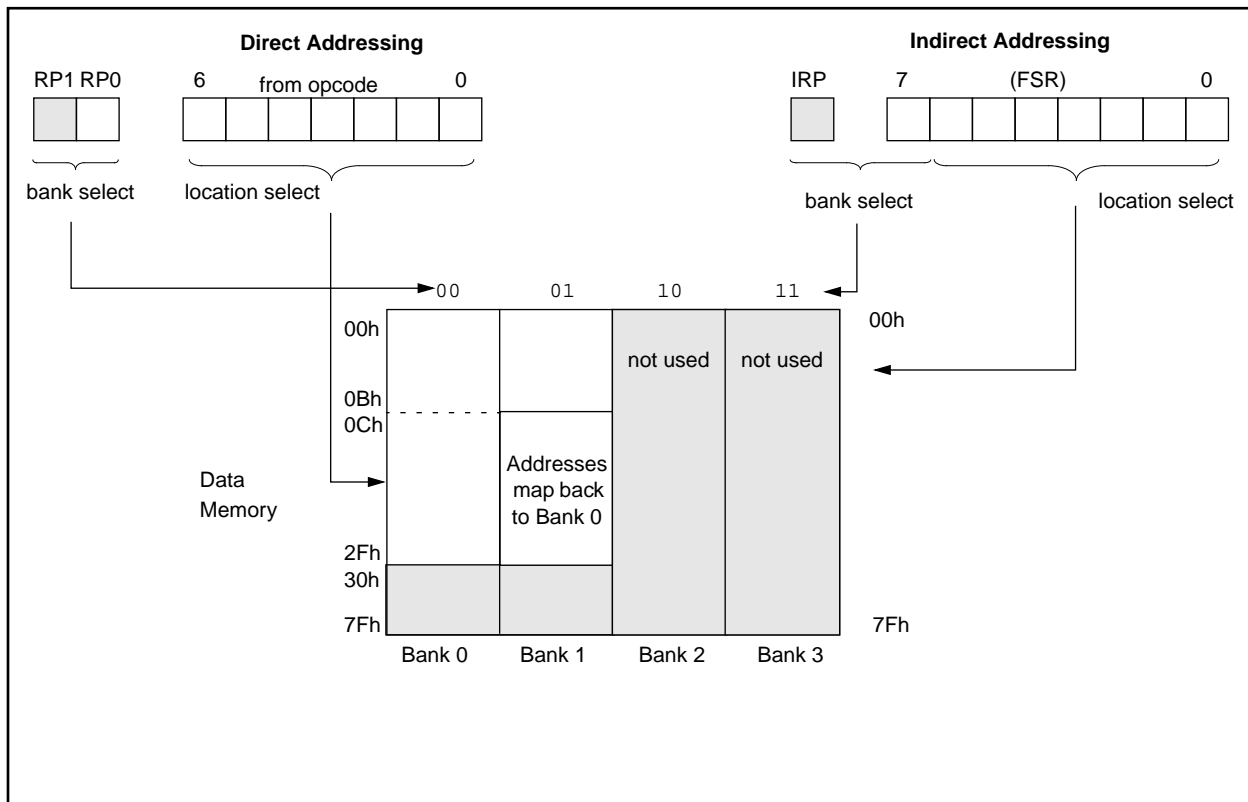

5.0 I/O PORTS

The PIC16C84 has two ports, PORTA and PORTB. Some port pins are multiplexed with an alternate function for other features on the device.

5.1 PORTA and TRISA Registers

PORTA is a 5-bit wide latch. RA4 is a Schmitt Trigger input and an open drain output. All other RA port pins have TTL input levels and full CMOS output drivers. All pins have data direction bits (TRIS registers) which can configure these pins as output or input.

Setting a TRISA bit (=1) will make the corresponding PORTA pin an input, i.e., put the corresponding output driver in a hi-impedance mode. Clearing a TRISA bit (=0) will make the corresponding PORTA pin an output, i.e., put the contents of the output latch on the selected pin.

Reading the PORTA register reads the status of the pins whereas writing to it will write to the port latch. All write operations are read-modify-write operations. So a write to a port implies that the port pins are first read, then this value is modified and written to the port data latch.

The RA4 pin is multiplexed with the TMR0 clock input.

FIGURE 5-1: BLOCK DIAGRAM OF PINS RA3:RA0

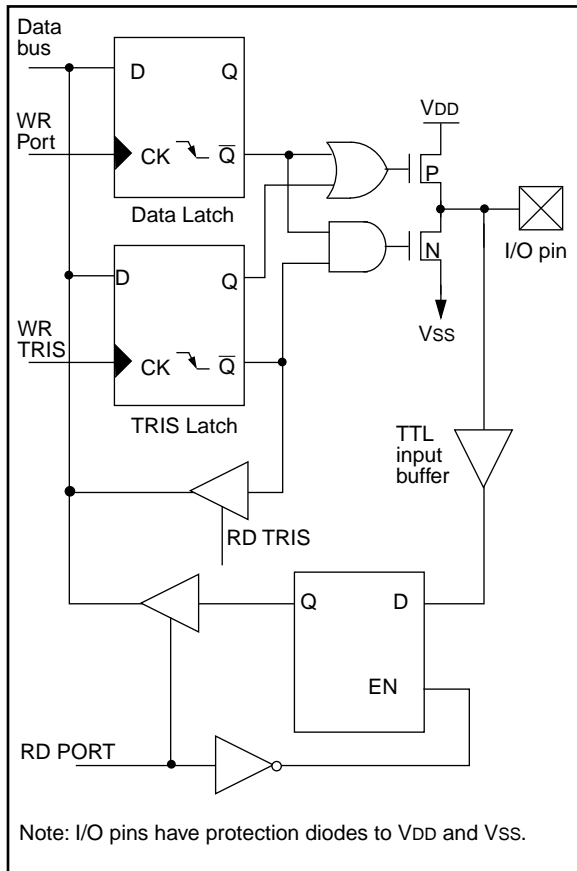

EXAMPLE 5-1: INITIALIZING PORTA

```
CLRF  PORTA      ; Initialize PORTA by
                ; setting output
                ; data latches
BSF   STATUS, RP0 ; Select Bank 1
MOVLW 0x0F      ; Value used to
                ; initialize data
                ; direction
MOVWF  TRISA     ; Set RA<3:0> as inputs
                ; RA4 as outputs
                ; TRISA<7:5> are always
                ; read as '0'.
```

FIGURE 5-2: BLOCK DIAGRAM OF PIN RA4

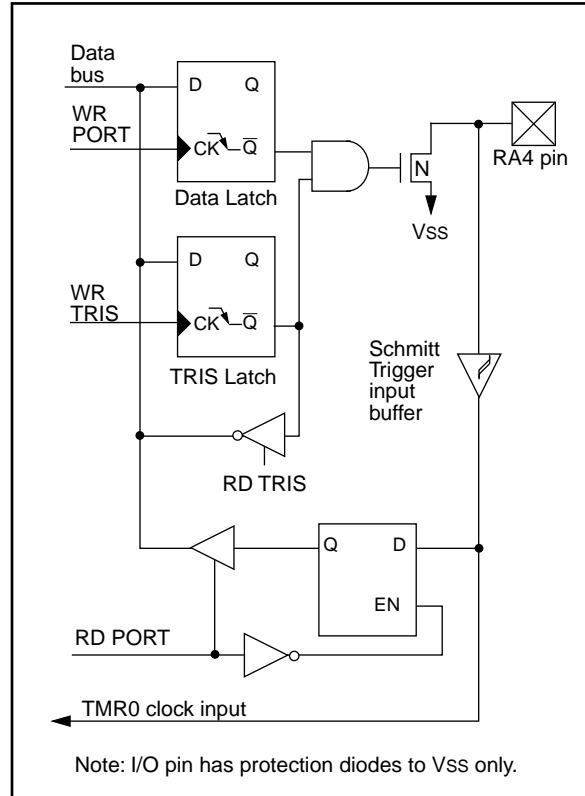

Note: For crystal oscillator configurations operating below 500 kHz, the device may generate a spurious internal Q-clock when PORTA<0> switches state. This does not occur with an external clock in RC mode. To avoid this, the RA0 pin should be kept static, i.e. in input/output mode, pin RA0 should not be toggled.

PIC16C84

TABLE 5-1 PORTA FUNCTIONS

Name	Bit0	Buffer Type	Function
RA0	bit0	TTL	Input/output
RA1	bit1	TTL	Input/output
RA2	bit2	TTL	Input/output
RA3	bit3	TTL	Input/output
RA4/T0CKI	bit4	ST	Input/output or external clock input for TMR0. Output is open drain type.

Legend: TTL = TTL input, ST = Schmitt Trigger input

TABLE 5-2 SUMMARY OF REGISTERS ASSOCIATED WITH PORTA

Address	Name	Bit 7	Bit 6	Bit 5	Bit 4	Bit 3	Bit 2	Bit 1	Bit 0	Value on Power-on Reset	Value on all other resets
05h	PORTA	—	—	—	RA4/T0CKI	RA3	RA2	RA1	RA0	---x xxxx	---u uuuu
85h	TRISA	—	—	—	TRISA4	TRISA3	TRISA2	TRISA1	TRISA0	---1 1111	---1 1111

Legend: x = unknown, u = unchanged, - = unimplemented read as '0'. Shaded cells are unimplemented, read as '0'

5.2 PORTB and TRISB Registers

PORTB is an 8-bit wide bi-directional port. The corresponding data direction register is TRISB. A '1' on any bit in the TRISB register puts the corresponding output driver in a hi-impedance mode. A '0' on any bit in the TRISB register puts the contents of the output latch on the selected pin(s).

Each of the PORTB pins have a weak internal pull-up. A single control bit can turn on all the pull-ups. This is done by clearing the RBP_U (OPTION_REG<7>) bit. The weak pull-up is automatically turned off when the port pin is configured as an output. The pull-ups are disabled on a Power-on Reset.

Four of PORTB's pins, RB7:RB4, have an interrupt on change feature. Only pins configured as inputs can cause this interrupt to occur (i.e., any RB7:RB4 pin configured as an output is excluded from the interrupt on change comparison). The pins value in input mode are compared with the old value latched on the last read of PORTB. The "mismatch" outputs of the pins are OR'ed together to generate the RB port change interrupt.

FIGURE 5-3: BLOCK DIAGRAM OF PINS RB7:RB4

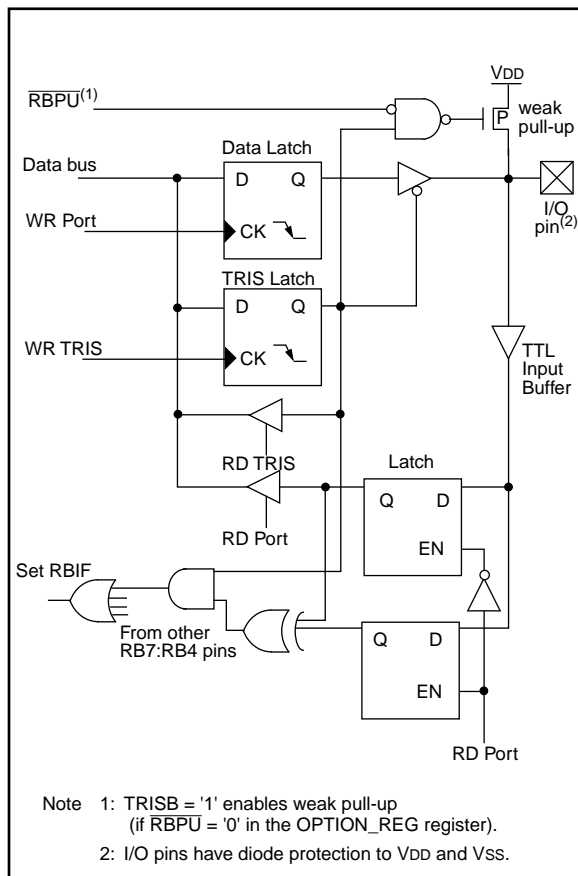

This interrupt can wake the device from SLEEP. The user, in the interrupt service routine, can clear the interrupt in the following manner:

- Read (or write) PORTB. This will end the mismatch condition.
- Clear flag bit RBIF.

A mismatch condition will continue to set the RBIF bit. Reading PORTB will end the mismatch condition, and allow the RBIF bit to be cleared.

This interrupt on mismatch feature, together with software configurable pull-ups on these four pins allow easy interface to a key pad and make it possible for wake-up on key-depression (see AN552 in the Embedded Control Handbook).

Note 1: If a change on the I/O pin should occur when a read operation of PORTB is being executed (start of the Q2 cycle), the RBIF interrupt flag bit may not be set.

The interrupt on change feature is recommended for wake-up on key depression operation and operations where PORTB is only used for the interrupt on change feature. Polling of PORTB is not recommended while using the interrupt on change feature.

FIGURE 5-4: BLOCK DIAGRAM OF PINS RB3:RB0

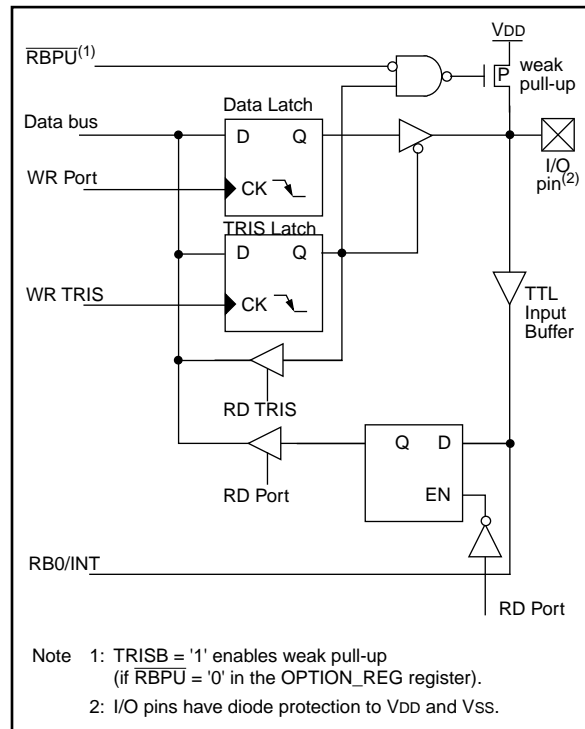

PIC16C84

EXAMPLE 5-1: INITIALIZING PORTB

```

CLRF   PORTB           ; Initialize PORTB by
                        ; setting output
                        ; data latches
BSF    STATUS, RP0    ; Select Bank 1
MOVLW  0xCF           ; Value used to
                        ; initialize data
                        ; direction
MOVWF  TRISB          ; Set RB<3:0> as inputs
                        ; RB<5:4> as outputs
                        ; RB<7:6> as inputs
    
```

TABLE 5-3 PORTB FUNCTIONS

Name	Bit	Buffer Type	I/O Consistency Function
RB0/INT	bit0	TTL	Input/output pin or external interrupt input. Internal software programmable weak pull-up.
RB1	bit1	TTL	Input/output pin. Internal software programmable weak pull-up.
RB2	bit2	TTL	Input/output pin. Internal software programmable weak pull-up.
RB3	bit3	TTL	Input/output pin. Internal software programmable weak pull-up.
RB4	bit4	TTL	Input/output pin (with interrupt on change). Internal software programmable weak pull-up.
RB5	bit5	TTL	Input/output pin (with interrupt on change). Internal software programmable weak pull-up.
RB6	bit6	TTL/ST ⁽¹⁾	Input/output pin (with interrupt on change). Internal software programmable weak pull-up. Serial programming clock.
RB7	bit7	TTL/ST ⁽¹⁾	Input/output pin (with interrupt on change). Internal software programmable weak pull-up. Serial programming data.

Legend: TTL = TTL input, ST = Schmitt Trigger.

Note 1: This buffer is a Schmitt Trigger input when used in serial programming mode.

TABLE 5-4 SUMMARY OF REGISTERS ASSOCIATED WITH PORTB

Address	Name	Bit 7	Bit 6	Bit 5	Bit 4	Bit 3	Bit 2	Bit 1	Bit 0	Value on Power-on Reset	Value on all other resets
06h	PORTB	RB7	RB6	RB5	RB4	RB3	RB2	RB1	RB0/INT	xxxx xxxx	uuuu uuuu
86h	TRISB	TRISB7	TRISB6	TRISB5	TRISB4	TRISB3	TRISB2	TRISB1	TRISB0	1111 1111	1111 1111
81h	OPTION_REG	RBP _U	INTEDG	T0CS	T0SE	PSA	PS2	PS1	PS0	1111 1111	1111 1111

Legend: x = unknown, u = unchanged. Shaded cells are not used by PORTB.

5.3 I/O Programming Considerations

5.3.1 BI-DIRECTIONAL I/O PORTS

Any instruction which writes, operates internally as a read followed by a write operation. The `BCF` and `BSF` instructions, for example, read the register into the CPU, execute the bit operation and write the result back to the register. Caution must be used when these instructions are applied to a port with both inputs and outputs defined. For example, a `BSF` operation on bit5 of `PORTB` will cause all eight bits of `PORTB` to be read into the CPU. Then the `BSF` operation takes place on bit5 and `PORTB` is written to the output latches. If another bit of `PORTB` is used as a bi-directional I/O pin (i.e., bit0) and it is defined as an input at this time, the input signal present on the pin itself would be read into the CPU and rewritten to the data latch of this particular pin, overwriting the previous content. As long as the pin stays in the input mode, no problem occurs. However, if bit0 is switched into output mode later on, the content of the data latch is unknown.

Reading the port register, reads the values of the port pins. Writing to the port register writes the value to the port latch. When using read-modify-write instructions (i.e., `BCF`, `BSF`, etc.) on a port, the value of the port pins is read, the desired operation is done to this value, and this value is then written to the port latch.

A pin actively outputting a Low or High should not be driven from external devices at the same time in order to change the level on this pin ("wired-or", "wired-and"). The resulting high output current may damage the chip.

5.3.2 SUCCESSIVE OPERATIONS ON I/O PORTS

The actual write to an I/O port happens at the end of an instruction cycle, whereas for reading, the data must be valid at the beginning of the instruction cycle (Figure 5-5). Therefore, care must be exercised if a write followed by a read operation is carried out on the same I/O port. The sequence of instructions should be such that the pin voltage stabilizes (load dependent) before the next instruction which causes that file to be read into the CPU is executed. Otherwise, the previous state of that pin may be read into the CPU rather than the new state. When in doubt, it is better to separate these instructions with a `NOP` or another instruction not accessing this I/O port.

Example 5-1 shows the effect of two sequential read-modify-write instructions (e.g., `BCF`, `BSF`, etc.) on an I/O port.

EXAMPLE 5-1: READ-MODIFY-WRITE INSTRUCTIONS ON AN I/O PORT

```

;Initial PORT settings: PORTB<7:4> Inputs
;                       PORTB<3:0> Outputs
;PORTB<7:6> have external pull-ups and are
;not connected to other circuitry
;
;
;                       PORT latch  PORT pins
;                       -----
BCF PORTB, 7           ; 01pp ppp   11pp ppp
BCF PORTB, 6           ; 10pp ppp   11pp ppp
BSF STATUS, RP0       ;
BCF TRISB, 7           ; 10pp ppp   11pp ppp
BCF TRISB, 6           ; 10pp ppp   10pp ppp
;
;Note that the user may have expected the
;pin values to be 00pp ppp. The 2nd BCF
;caused RB7 to be latched as the pin value
;(high).
    
```

FIGURE 5-5: SUCCESSIVE I/O OPERATION

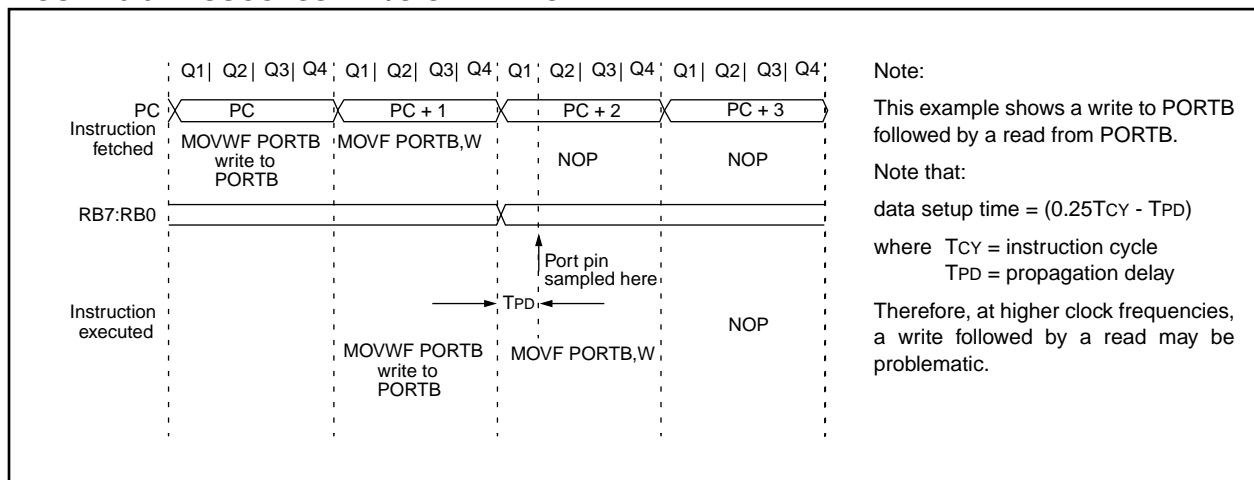

PIC16C84

NOTES:

6.0 TIMER0 MODULE AND TMR0 REGISTER

The Timer0 module timer/counter has the following features:

- 8-bit timer/counter
- Readable and writable
- 8-bit software programmable prescaler
- Internal or external clock select
- Interrupt on overflow from FFh to 00h
- Edge select for external clock

Timer mode is selected by clearing the T0CS bit (OPTION<5>). In timer mode, the Timer0 module (Figure 6-1) will increment every instruction cycle (without prescaler). If the TMR0 register is written, the increment is inhibited for the following two cycles (Figure 6-2 and Figure 6-3). The user can work around this by writing an adjusted value to the TMR0 register.

Counter mode is selected by setting the T0CS bit (OPTION<5>). In this mode TMR0 will increment either on every rising or falling edge of pin RA4/T0CKI. The incrementing edge is determined by the T0 source

edge select bit, T0SE (OPTION<4>). Clearing bit T0SE selects the rising edge. Restrictions on the external clock input are discussed in detail in Section 6.2.

The prescaler is shared between the Timer0 Module and the Watchdog Timer. The prescaler assignment is controlled, in software, by control bit PSA (OPTION<3>). Clearing bit PSA will assign the prescaler to the Timer0 Module. The prescaler is not readable or writable. When the prescaler (Section 6.3) is assigned to the Timer0 Module, the prescale value (1:2, 1:4, ..., 1:256) is software selectable.

6.1 TMR0 Interrupt

The TMR0 interrupt is generated when the TMR0 register overflows from FFh to 00h. This overflow sets the TOIF bit (INTCON<2>). The interrupt can be masked by clearing enable bit T0IE (INTCON<5>). The TOIF bit must be cleared in software by the Timer0 Module interrupt service routine before re-enabling this interrupt. The TMR0 interrupt (Figure 6-4) cannot wake the processor from SLEEP since the timer is shut off during SLEEP.

FIGURE 6-1: TMR0 BLOCK DIAGRAM

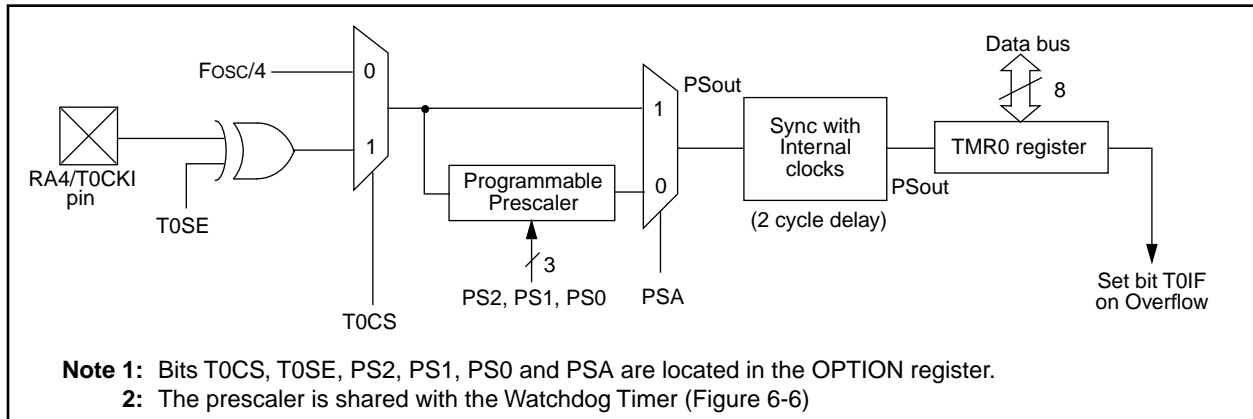
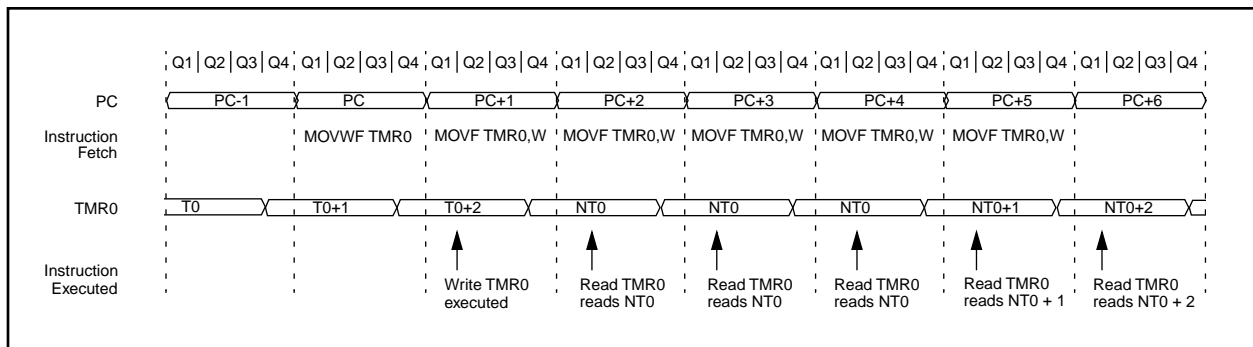

FIGURE 6-2: TMR0 TIMING: INTERNAL CLOCK/NO PRESCALER



PIC16C84

FIGURE 6-3: TMR0 TIMING: INTERNAL CLOCK/PRESCALE 1:2

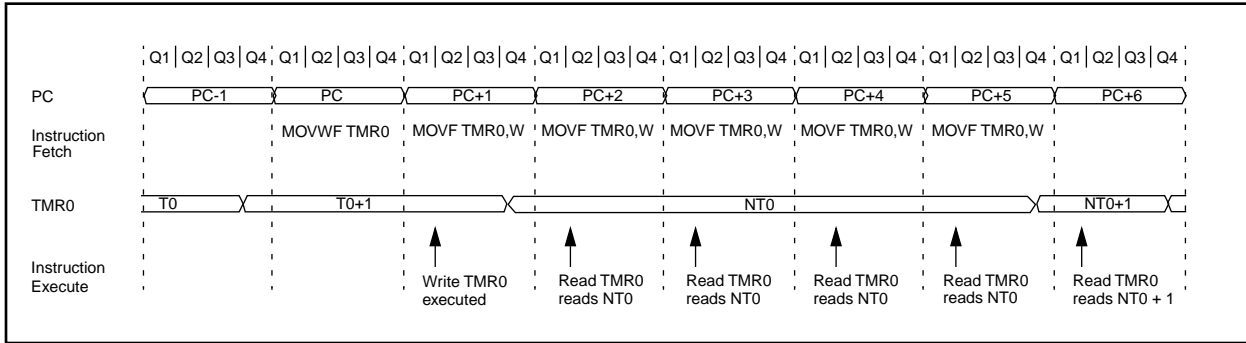
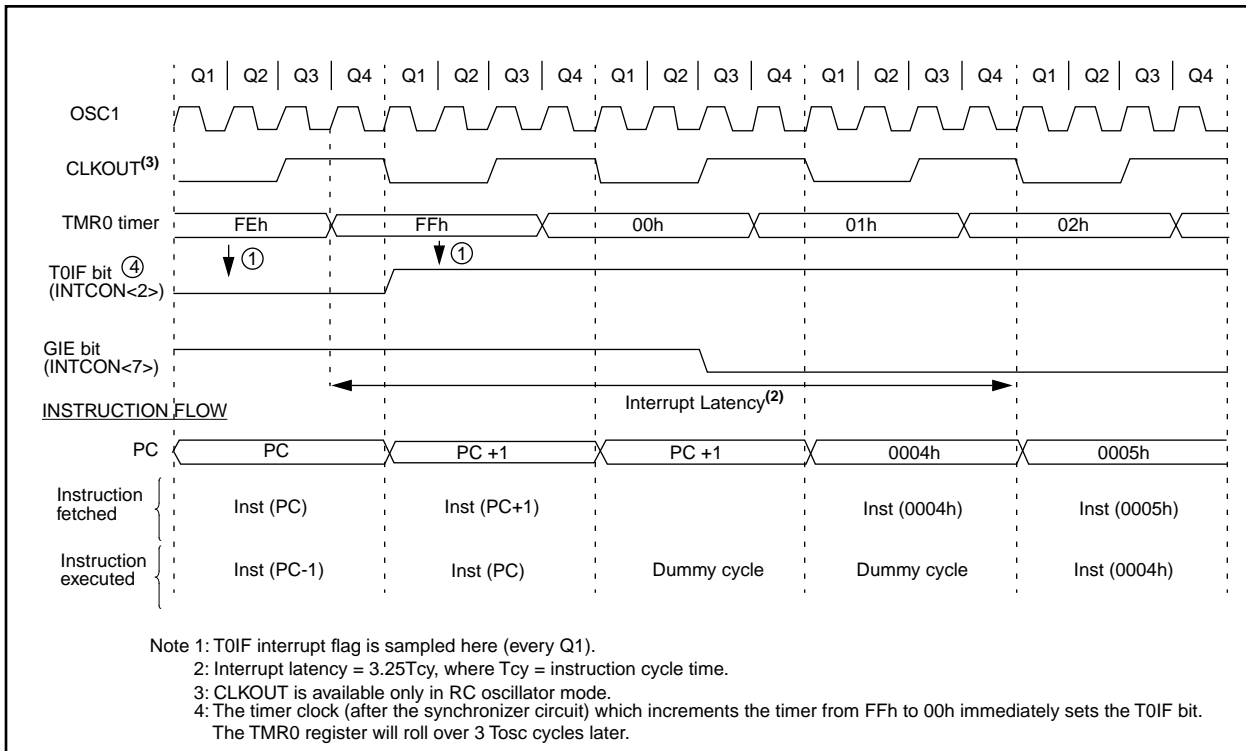

FIGURE 6-4: TMR0 INTERRUPT TIMING



6.2 Using TMR0 with External Clock

When an external clock input is used for TMR0, it must meet certain requirements. The external clock requirement is due to internal phase clock (Tosc) synchronization. Also, there is a delay in the actual incrementing of the TMR0 register after synchronization.

6.2.1 EXTERNAL CLOCK SYNCHRONIZATION

When no prescaler is used, the external clock input is the same as the prescaler output. The synchronization of pin RA4/T0CKI with the internal phase clocks is accomplished by sampling the prescaler output on the Q2 and Q4 cycles of the internal phase clocks (Figure 6-5). Therefore, it is necessary for T0CKI to be high for at least $2T_{osc}$ (plus a small RC delay) and low for at least $2T_{osc}$ (plus a small RC delay). Refer to the electrical specification of the desired device.

When a prescaler is used, the external clock input is divided by an asynchronous ripple counter type prescaler so that the prescaler output is symmetrical. For the external clock to meet the sampling requirement, the ripple counter must be taken into account. Therefore, it is necessary for T0CKI to have a period of at least $4T_{osc}$ (plus a small RC delay) divided by the prescaler value. The only requirement on T0CKI high and low time is that they do not violate the minimum pulse width requirement of 10 ns. Refer to parameters 40, 41 and 42 in the AC Electrical Specifications of the desired device.

6.2.2 TMR0 INCREMENT DELAY

Since the prescaler output is synchronized with the internal clocks, there is a small delay from the time the external clock edge occurs to the time the Timer0 Module is actually incremented. Figure 6-5 shows the delay from the external clock edge to the timer incrementing.

6.3 Prescaler

An 8-bit counter is available as a prescaler for the Timer0 Module, or as a postscaler for the Watchdog Timer (Figure 6-6). For simplicity, this counter is being referred to as "prescaler" throughout this data sheet. Note that there is only one prescaler available which is mutually exclusive between the Timer0 Module and the Watchdog Timer. Thus, a prescaler assignment for the Timer0 Module means that there is no prescaler for the Watchdog Timer, and vice-versa.

The PSA and PS2:PS0 bits (OPTION<3:0>) determine the prescaler assignment and prescale ratio.

When assigned to the Timer0 Module, all instructions writing to the Timer0 Module (e.g., `CLRF 1`, `MOVWF 1`, `BSF 1,x` ...etc.) will clear the prescaler. When assigned to WDT, a `CLRWDT` instruction will clear the prescaler along with the Watchdog Timer. The prescaler is not readable or writable.

FIGURE 6-5: TIMER0 TIMING WITH EXTERNAL CLOCK

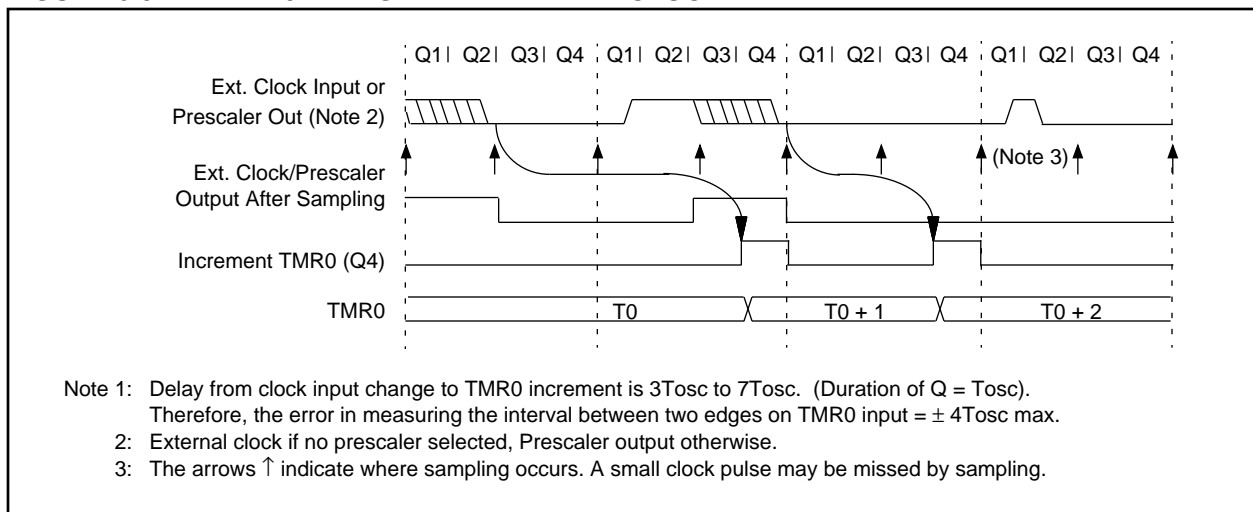

PIC16C84

FIGURE 6-6: BLOCK DIAGRAM OF THE TMR0/WDT PRESCALER

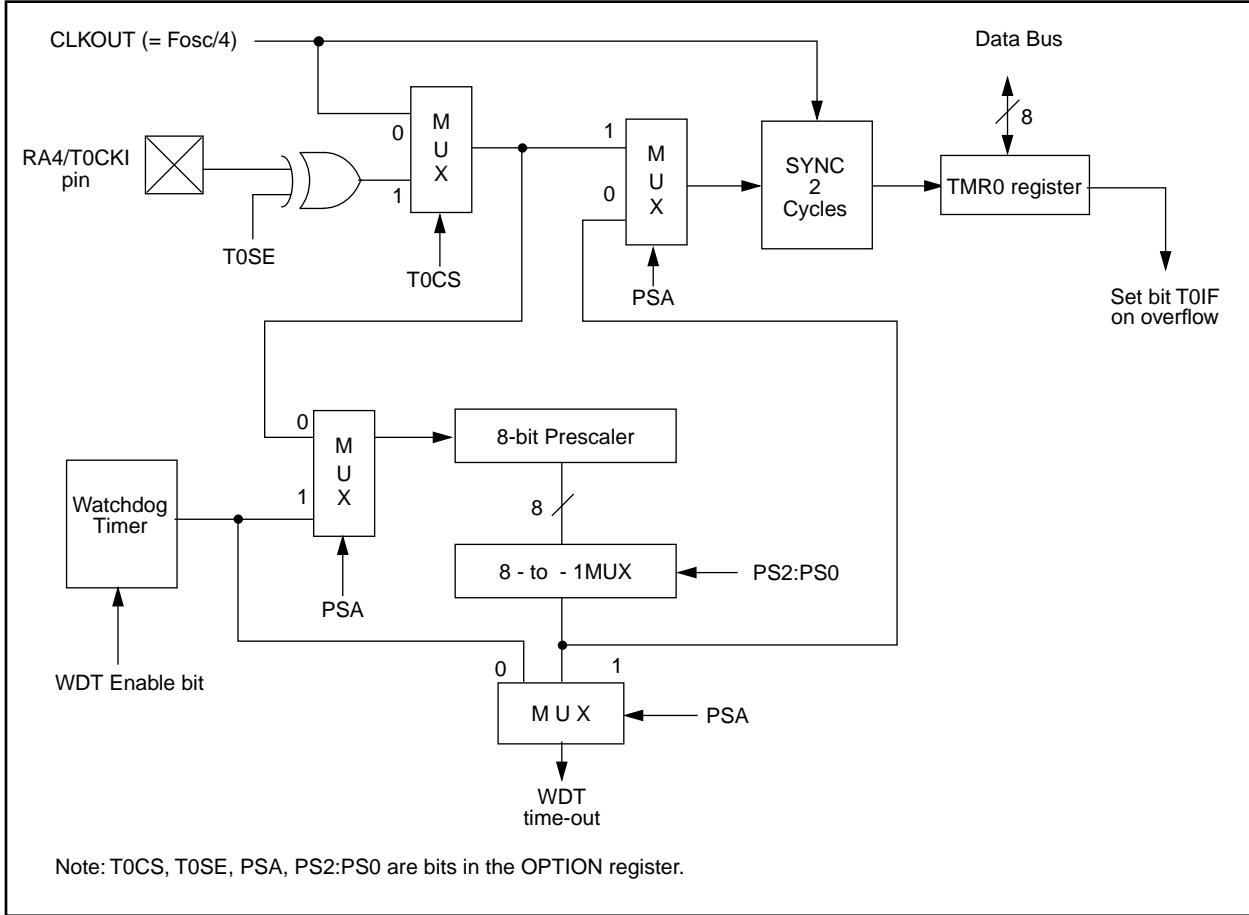

6.3.1 SWITCHING PRESCALER ASSIGNMENT

The prescaler assignment is fully under software control (i.e., it can be changed “on the fly” during program execution).

Note: To avoid an unintended device RESET, the following instruction sequence (Example 6-1) must be executed when changing the prescaler assignment from Timer0 to the WDT. This sequence must be taken even if the WDT is disabled. To change prescaler from the WDT to the Timer0 module use the sequence shown in Example 6-2.

EXAMPLE 6-1: CHANGING PRESCALER (TIMER0→WDT)

```
BCF STATUS, RP0 ;Bank 0
CLRF TMR0 ;Clear TMR0
; and Prescaler

BSF STATUS, RP0 ;Bank 1
CLRWDT ;Clears WDT
MOVLW b'xxxx1xxx' ;Select new
MOVWF OPTION ; prescale value
BCF STATUS, RP0 ;Bank 0
```

EXAMPLE 6-2: CHANGING PRESCALER (WDT→TIMER0)

```
CLRWDT ;Clear WDT and
; prescaler

BSF STATUS, RP0 ;Bank 1
MOVLW b'xxxx0xxx' ;Select TMR0, new
; prescale value
; and clock source

MOVWF OPTION ;
BCF STATUS, RP0 ;Bank 0
```

TABLE 6-1 REGISTERS ASSOCIATED WITH TIMER0

Address	Name	Bit 7	Bit 6	Bit 5	Bit 4	Bit 3	Bit 2	Bit 1	Bit 0	Value on Power-on Reset	Value on all other resets
01h	TMR0	Timer0 module's register								xxxx xxxx	uuuu uuuu
0Bh	INTCON	GIE	EEIE	T0IE	INTE	RBIE	T0IF	INTF	RBIF	0000 000x	0000 0000
81h	OPTION	RBPU	INTEDG	T0CS	T0SE	PSA	PS2	PS1	PS0	1111 1111	1111 1111
85h	TRISA	—	—	—	TRISA4	TRISA3	TRISA2	TRISA1	TRISA0	---1 1111	---1 1111

Legend: x = unknown, u = unchanged. - = unimplemented read as '0'. Shaded cells are not associated with Timer0.

PIC16C84

NOTES:

7.0 DATA EEPROM MEMORY

The EEPROM data memory is readable and writable during normal operation (full VDD range). This memory is not directly mapped in the register file space. Instead it is indirectly addressed through the Special Function Registers. There are four SFRs used to read and write this memory. These registers are:

- EECON1
- EECON2
- EEDATA
- EEADR

EEDATA holds the 8-bit data for read/write, and EEADR holds the address of the EEPROM location being accessed. PIC16C84 devices have 64 bytes of data EEPROM with an address range from 0h to 3Fh.

The EEPROM data memory allows byte read and write. A byte write automatically erases the location and writes the new data (erase before write). The EEPROM data memory is rated for high erase/write cycles. The write time is controlled by an on-chip timer. The write-time will vary with voltage and temperature as well as from chip to chip. Please refer to AC specifications for exact limits.

When the device is code protected, the CPU may continue to read and write the data EEPROM memory. The device programmer can no longer access this memory.

7.1 EEADR

The EEADR register can address up to a maximum of 256 bytes of data EEPROM. Only the first 64 bytes of data EEPROM are implemented.

The upper two bits are address decoded. This means that these two bits must always be '0' to ensure that the address is in the 64 byte memory space.

FIGURE 7-1: EECON1 REGISTER (ADDRESS 88h)

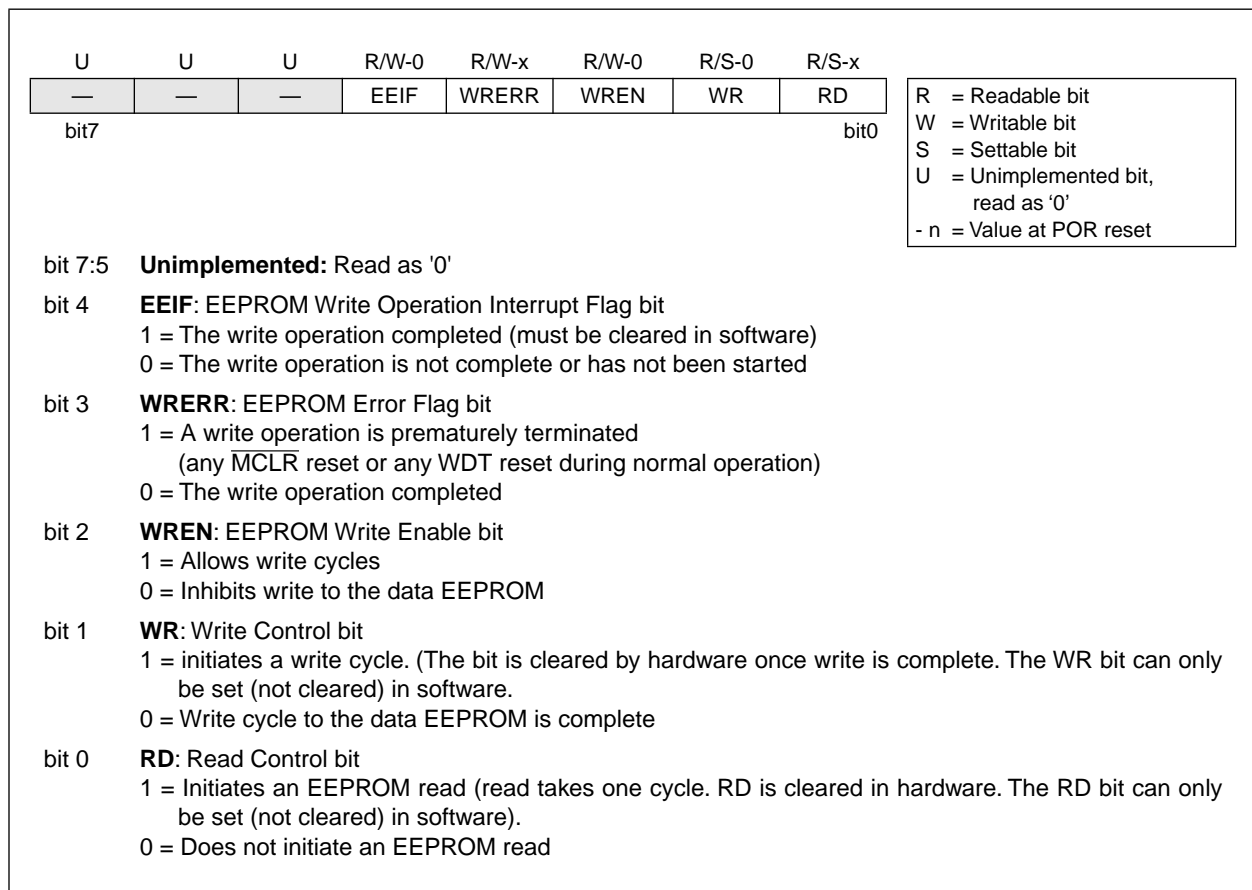

7.2 EECON1 and EECON2 Registers

EECON1 is the control register with five low order bits physically implemented. The upper-three bits are non-existent and read as '0's.

Control bits RD and WR initiate read and write, respectively. These bits cannot be cleared, only set, in software. They are cleared in hardware at completion of the read or write operation. The inability to clear the WR bit in software prevents the accidental, premature termination of a write operation.

The WREN bit, when set, will allow a write operation. On power-up, the WREN bit is clear. The WRERR bit is set when a write operation is interrupted by a MCLR reset or a WDT time-out reset during normal operation. In these situations, following reset, the user can check the WRERR bit and rewrite the location. The data and address will be unchanged in the EEDATA and EEADR registers.

Interrupt flag bit EEIF is set when write is complete. It must be cleared in software.

EECON2 is not a physical register. Reading EECON2 will read all '0's. The EECON2 register is used exclusively in the Data EEPROM write sequence.

7.3 Reading the EEPROM Data Memory

To read a data memory location, the user must write the address to the EEADR register and then set control bit RD (EECON1<0>). The data is available, in the very next cycle, in the EEDATA register; therefore it can be read in the next instruction. EEDATA will hold this value until another read or until it is written to by the user (during a write operation).

EXAMPLE 7-1: DATA EEPROM READ

```
BCF     STATUS, RP0 ; Bank 0
MOVLW  CONFIG_ADDR ;
MOVWF  EEADR      ; Address to read
BSF     STATUS, RP0 ; Bank 1
BSF     EECON1, RD ; EE Read
BCF     STATUS, RP0 ; Bank 0
MOVF   EEDATA, W  ; W = EEDATA
```

7.4 Writing to the EEPROM Data Memory

To write an EEPROM data location, the user must first write the address to the EEADR register and the data to the EEDATA register. Then the user must follow a specific sequence to initiate the write for each byte.

EXAMPLE 7-1: DATA EEPROM WRITE

```
BSF     STATUS, RP0 ; Bank 1
BCF     INTCON, GIE ; Disable INTs.
BSF     EECON1, WREN ; Enable Write
MOVLW  55h          ;
```

Required Sequence	MOVWF	EECON2	; Write 55h
	MOVLW	AAh	;
	MOVWF	EECON2	; Write AAh
	BSF	EECON1,WR	; Set WR bit
			; begin write
	BSF	INTCON, GIE	; Enable INTs.

The write will not initiate if the above sequence is not exactly followed (write 55h to EECON2, write AAh to EECON2, then set WR bit) for each byte. We strongly recommend that interrupts be disabled during this code segment.

Additionally, the WREN bit in EECON1 must be set to enable write. This mechanism prevents accidental writes to data EEPROM due to errant (unexpected) code execution (i.e., lost programs). The user should keep the WREN bit clear at all times, except when updating EEPROM. The WREN bit is not cleared by hardware.

After a write sequence has been initiated, clearing the WREN bit will not affect this write cycle. The WR bit will be inhibited from being set unless the WREN bit is set.

At the completion of the write cycle, the WR bit is cleared in hardware and the EE Write Complete Interrupt Flag bit (EEIF) is set. The user can either enable this interrupt or poll this bit. EEIF must be cleared by software.

Note: The data EEPROM memory E/W cycle time may occasionally exceed the 10 ms specification (typical). To ensure that the write cycle is complete, use the EE interrupt or poll the WR bit (EECON1<1>). Both these events signify the completion of the write cycle.

7.5 Write Verify

Depending on the application, good programming practice may dictate that the value written to the Data EEPROM should be verified (Example 7-1) to the desired value to be written. This should be used in applications where an EEPROM bit will be stressed near the specification limit. The Total Endurance disk will help determine your comfort level.

Generally the EEPROM write failure will be a bit which was written as a '1', but reads back as a '0' (due to leakage off the bit).

EXAMPLE 7-1: WRITE VERIFY

```

BCF STATUS, RP0 ; Bank 0
:                ; Any code can go here
:                ;
MOVWF EEDATA, W ; Must be in Bank 0
BSF STATUS, RP0 ; Bank 1
READ
BSF EECON1, RD ; YES, Read the
                ; value written
BCF STATUS, RP0 ; Bank 0
;
; Is the value written (in W reg) and
; read (in EEDATA) the same?
;
SUBWF EEDATA, W ;
BTFSS STATUS, Z ; Is difference 0?
GOTO WRITE_ERR ; NO, Write error
:                ; YES, Good write
:                ; Continue program
    
```

7.6 Protection Against Spurious Writes

There are conditions when the device may not want to write to the data EEPROM memory. To protect against spurious EEPROM writes, various mechanisms have been built in. On power-up, WREN is cleared. Also, the Power-up Timer (72 ms duration) prevents EEPROM write.

The write initiate sequence and the WREN bit together help prevent an accidental write during brown-out, power glitch, or software malfunction.

7.7 Data EEPROM Operation during Code Protect

When the device is code protected, the CPU is able to read and write unscrambled data to the Data EEPROM.

For ROM devices, there are two code protection bits (Section 8.1). One for the ROM program memory and one for the Data EEPROM memory.

7.8 Power Consumption Considerations

Note: It is recommended that the EEADR<7:6> bits be cleared. When either of these bits is set, the maximum IDD for the device is higher than when both are cleared. The specification is 400 μ A. With EEADR<7:6> cleared, the maximum is approximately 150 μ A.

TABLE 7-1 REGISTERS/BITS ASSOCIATED WITH DATA EEPROM

Address	Name	Bit 7	Bit 6	Bit 5	Bit 4	Bit 3	Bit 2	Bit 1	Bit 0	Value on Power-on Reset	Value on all other resets
08h	EEDATA	EEPROM data register								xxxx xxxx	uuuu uuuu
09h	EEADR	EEPROM address register								xxxx xxxx	uuuu uuuu
88h	EECON1	—	—	—	EEIF	WRERR	WREN	WR	RD	---0 x000	---0 q000
89h	EECON2	EEPROM control register 2								---- ----	---- ----

Legend: x = unknown, u = unchanged, - = unimplemented read as '0', q = value depends upon condition. Shaded cells are not used by Data EEPROM.

PIC16C84

NOTES:

8.0 SPECIAL FEATURES OF THE CPU

What sets a microcontroller apart from other processors are special circuits to deal with the needs of real time applications. The PIC16C84 has a host of such features intended to maximize system reliability, minimize cost through elimination of external components, provide power saving operating modes and offer code protection. These features are:

- OSC selection
- Reset
 - Power-on Reset (POR)
 - Power-up Timer (PWRT)
 - Oscillator Start-up Timer (OST)
- Interrupts
- Watchdog Timer (WDT)
- SLEEP
- Code protection
- ID locations
- In-circuit serial programming

The PIC16C84 has a Watchdog Timer which can be shut off only through configuration bits. It runs off its own RC oscillator for added reliability. There are two timers that offer necessary delays on power-up. One is the Oscillator Start-up Timer (OST), intended to keep

the chip in reset until the crystal oscillator is stable. The other is the Power-up Timer (PWRT), which provides a fixed delay of 72 ms (nominal) on power-up only. This design keeps the device in reset while the power supply stabilizes. With these two timers on-chip, most applications need no external reset circuitry.

SLEEP mode offers a very low current power-down mode. The user can wake-up from SLEEP through external reset, Watchdog Timer time-out or through an interrupt. Several oscillator options are provided to allow the part to fit the application. The RC oscillator option saves system cost while the LP crystal option saves power. A set of configuration bits are used to select the various options.

8.1 Configuration Bits

The configuration bits can be programmed (read as '0') or left unprogrammed (read as '1') to select various device configurations. These bits are mapped in program memory location 2007h.

Address 2007h is beyond the user program memory space and it belongs to the special test/configuration memory space (2000h - 3FFFh). This space can only be accessed during programming.

To find out how to program the PIC16C84, refer to *PIC16C84 EEPROM Memory Programming Specification* (DS30189).

FIGURE 8-1: CONFIGURATION WORD

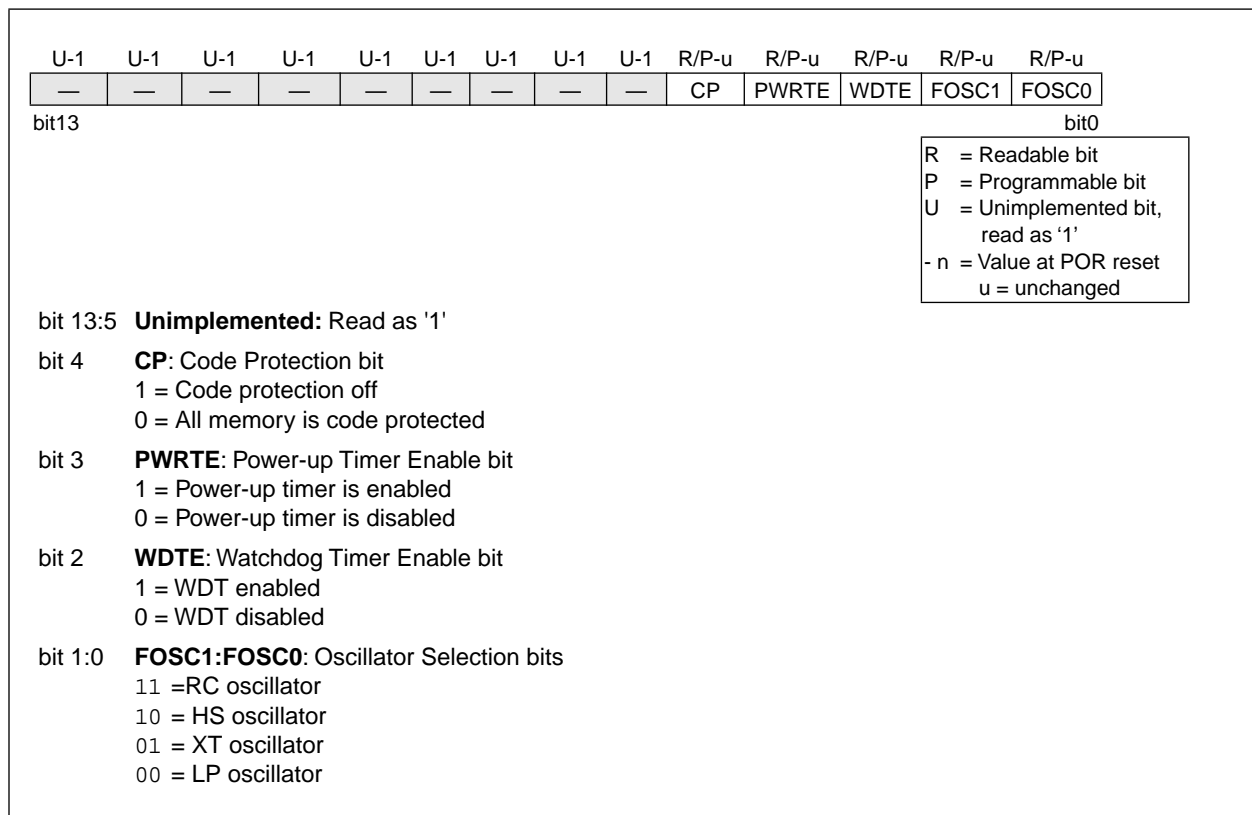

PIC16C84

8.2 Oscillator Configurations

8.2.1 OSCILLATOR TYPES

The PIC16C84 can be operated in four different oscillator modes. The user can program two configuration bits (FOSC1 and FOSC0) to select one of these four modes:

- LP Low Power Crystal
- XT Crystal/Resonator
- HS High Speed Crystal/Resonator
- RC Resistor/Capacitor

8.2.2 CRYSTAL OSCILLATOR / CERAMIC RESONATORS

In XT, LP or HS modes a crystal or ceramic resonator is connected to the OSC1/CLKIN and OSC2/CLKOUT pins to establish oscillation (Figure 8-2).

FIGURE 8-2: CRYSTAL/CERAMIC RESONATOR OPERATION (HS, XT OR LP OSC CONFIGURATION)

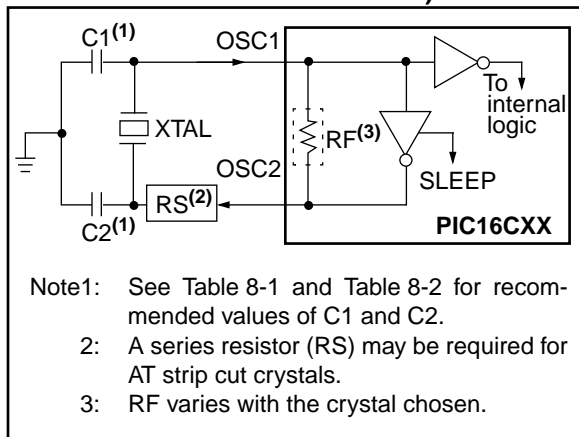

The PIC16C84 oscillator design requires the use of a parallel cut crystal. Use of a series cut crystal may give a frequency out of the crystal manufacturers specifications. When in XT, LP or HS modes, the device can have an external clock source to drive the OSC1/CLKIN pin (Figure 8-3).

FIGURE 8-3: EXTERNAL CLOCK INPUT OPERATION (HS, XT OR LP OSC CONFIGURATION)

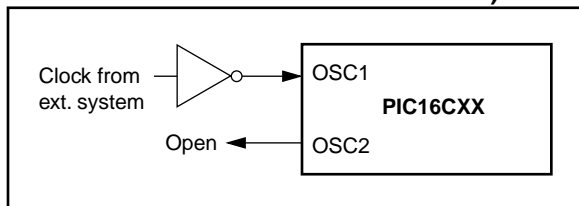

TABLE 8-1 CAPACITOR SELECTION FOR CERAMIC RESONATORS

Ranges Tested:			
Mode	Freq	OSC1/C1	OSC2/C2
XT	455 kHz	47 - 100 pF	47 - 100 pF
	2.0 MHz	15 - 33 pF	15 - 33 pF
	4.0 MHz	15 - 33 pF	15 - 33 pF
HS	8.0 MHz	15 - 33 pF	15 - 33 pF
	10.0 MHz	15 - 33 pF	15 - 33 pF

Note: Recommended values of C1 and C2 are identical to the ranges tested table.
 Higher capacitance increases the stability of the oscillator but also increases the start-up time. These values are for design guidance only. Since each resonator has its own characteristics, the user should consult the resonator manufacturer for the appropriate values of external components.

Resonators Tested:

455 kHz	Panasonic EFO-A455K04B	± 0.3%
2.0 MHz	Murata Erie CSA2.00MG	± 0.5%
4.0 MHz	Murata Erie CSA4.00MG	± 0.5%
8.0 MHz	Murata Erie CSA8.00MT	± 0.5%
10.0 MHz	Murata Erie CSA10.00MTZ	± 0.5%

None of the resonators had built-in capacitors.

TABLE 8-2 CAPACITOR SELECTION FOR CRYSTAL OSCILLATOR

Mode	Freq	OSC1/C1	OSC2/C2
LP	32 kHz	68 - 100 pF	68 - 100 pF
	200 kHz	15 - 33 pF	15 - 33 pF
XT	100 kHz	100 - 150 pF	100 - 150 pF
	2 MHz	15 - 33 pF	15 - 33 pF
	4 MHz	15 - 33 pF	15 - 33 pF
HS	4 MHz	15 - 33 pF	15 - 33 pF
	10 MHz	15 - 33 pF	15 - 33 pF

Note: Higher capacitance increases the stability of oscillator but also increases the start-up time. These values are for design guidance only. Rs may be required in HS mode as well as XT mode to avoid overdriving crystals with low drive level specification. Since each crystal has its own characteristics, the user should consult the crystal manufacturer for appropriate values of external components.
 For VDD > 4.5V, C1 = C2 ≈ 30 pF is recommended.

Crystals Tested:

32.768 kHz	Epson C-001R32.768K-A	± 20 PPM
100 kHz	Epson C-2 100.00 KC-P	± 20 PPM
200 kHz	STD XTL 200.000 KHz	± 20 PPM
1.0 MHz	ECS ECS-10-13-2	± 50 PPM
2.0 MHz	ECS ECS-20-S-2	± 50 PPM
4.0 MHz	ECS ECS-40-S-4	± 50 PPM
10.0 MHz	ECS ECS-100-S-4	± 50 PPM

8.2.3 EXTERNAL CRYSTAL OSCILLATOR CIRCUIT

Either a prepackaged oscillator can be used or a simple oscillator circuit with TTL gates can be built. Prepackaged oscillators provide a wide operating range and better stability. A well-designed crystal oscillator will provide good performance with TTL gates. Two types of crystal oscillator circuits are available; one with series resonance, and one with parallel resonance.

Figure 8-4 shows a parallel resonant oscillator circuit. The circuit is designed to use the fundamental frequency of the crystal. The 74AS04 inverter performs the 180-degree phase shift that a parallel oscillator requires. The 4.7 kΩ resistor provides negative feedback for stability. The 10 kΩ potentiometer biases the 74AS04 in the linear region. This could be used for external oscillator designs.

FIGURE 8-4: EXTERNAL PARALLEL RESONANT CRYSTAL OSCILLATOR CIRCUIT

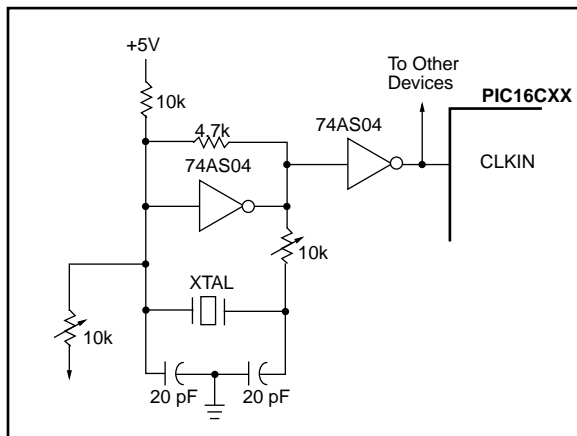
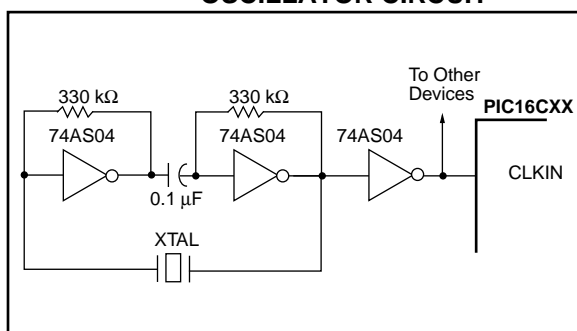

Figure 8-5 shows a series resonant oscillator circuit. This circuit is also designed to use the fundamental frequency of the crystal. The inverter performs a 180-degree phase shift. The 330 kΩ resistors provide the negative feedback to bias the inverters in their linear region.

FIGURE 8-5: EXTERNAL SERIES RESONANT CRYSTAL OSCILLATOR CIRCUIT



8.2.4 RC OSCILLATOR

For timing insensitive applications the RC device option offers additional cost savings. The RC oscillator frequency is a function of the supply voltage, the resistor (R_{ext}) values, capacitor (C_{ext}) values, and the operating temperature. In addition to this, the oscillator frequency will vary from unit to unit due to normal process parameter variation. Furthermore, the difference in lead frame capacitance between package types also affects the oscillation frequency, especially for low C_{ext} values. The user needs to take into account variation due to tolerance of the external R and C components. Figure 8-6 shows how an R/C combination is connected to the PIC16C84. For R_{ext} values below 2.2 kΩ, the oscillator operation may become unstable, or stop completely. For very high R_{ext} values (e.g., 1 MΩ), the oscillator becomes sensitive to noise, humidity and leakage. Thus, we recommend keeping R_{ext} between 3 kΩ and 100 kΩ.

Although the oscillator will operate with no external capacitor ($C_{ext} = 0$ pF), we recommend using values above 20 pF for noise and stability reasons. With little or no external capacitance, the oscillation frequency can vary dramatically due to changes in external capacitances, such as PCB trace capacitance or package lead frame capacitance.

See the electrical specification section for RC frequency variation from part to part due to normal process variation. The variation is larger for larger R (since leakage current variation will affect RC frequency more for large R) and for smaller C (since variation of input capacitance has a greater effect on RC frequency).

See the electrical specification section for variation of oscillator frequency due to V_{DD} for given R_{ext}/C_{ext} values as well as frequency variation due to operating temperature.

The oscillator frequency, divided by 4, is available on the OSC2/CLKOUT pin, and can be used for test purposes or to synchronize other logic (see Figure 3-2 for waveform).

FIGURE 8-6: RC OSCILLATOR MODE

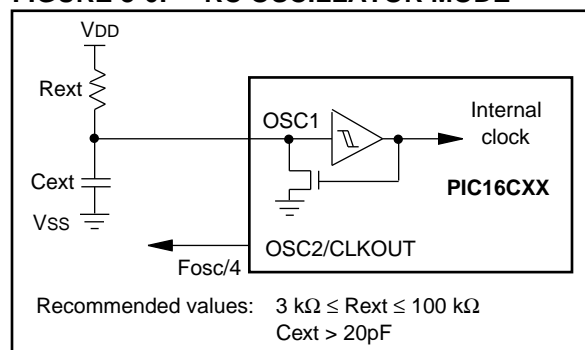

Note: When the device oscillator is in RC mode, do not drive the OSC1 pin with an external clock or you may damage the device.

PIC16C84

8.3 Reset

The PIC16C84 differentiates between various kinds of reset:

- Power-on Reset (POR)
- $\overline{\text{MCLR}}$ reset during normal operation
- $\overline{\text{MCLR}}$ reset during SLEEP
- WDT Reset (during normal operation)
- WDT Wake-up (during SLEEP)

Figure 8-7 shows a simplified block diagram of the on-chip reset circuit. The electrical specifications state the pulse width requirements for the $\overline{\text{MCLR}}$ pin.

Some registers are not affected in any reset condition; their status is unknown on a POR reset and unchanged in any other reset. Most other registers are reset to a "reset state" on POR, $\overline{\text{MCLR}}$ or WDT reset during normal operation and on $\overline{\text{MCLR}}$ reset during SLEEP. They are not affected by a WDT reset during SLEEP, since this reset is viewed as the resumption of normal operation.

Table 8-3 gives a description of reset conditions for the program counter (PC) and the STATUS register. Table 8-4 gives a full description of reset states for all registers.

The $\overline{\text{TO}}$ and $\overline{\text{PD}}$ bits are set or cleared differently in different reset situations (Section 8.7). These bits are used in software to determine the nature of the reset.

FIGURE 8-7: SIMPLIFIED BLOCK DIAGRAM OF ON-CHIP RESET CIRCUIT

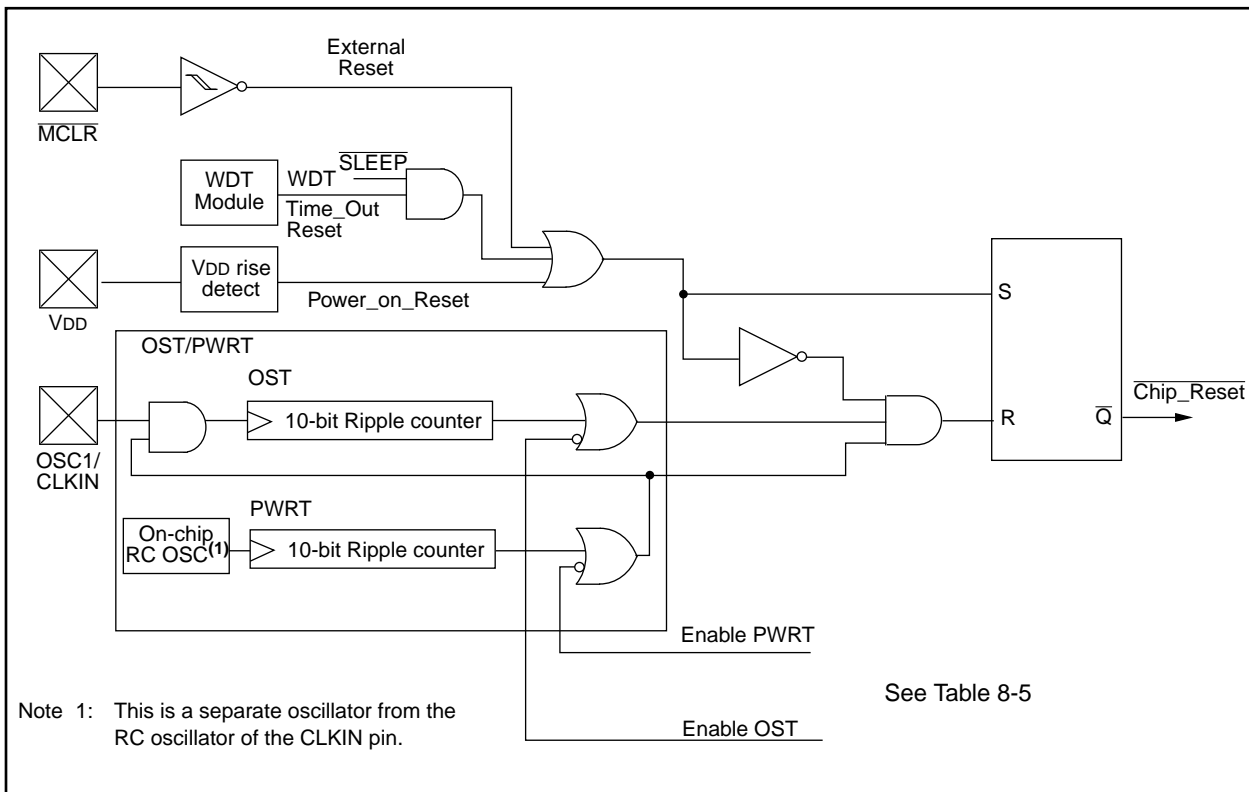

TABLE 8-3 RESET CONDITION FOR PROGRAM COUNTER AND THE STATUS REGISTER

Condition	Program Counter	STATUS Register
Power-on Reset	000h	0001 1xxx
MCLR Reset during normal operation	000h	000u uuuu
MCLR Reset during SLEEP	000h	0001 0uuu
WDT Reset (during normal operation)	000h	0000 1uuu
WDT Wake-up	PC + 1	uuu0 0uuu
Interrupt wake-up from SLEEP	PC + 1 ⁽¹⁾	uuu1 0uuu

Legend: u = unchanged, x = unknown.

Note 1: When the wake-up is due to an interrupt and the GIE bit is set, the PC is loaded with the interrupt vector (0004h).

TABLE 8-4 RESET CONDITIONS FOR ALL REGISTERS

Register	Address	Power-on Reset	MCLR Reset during: – normal operation – SLEEP WDT Reset during normal operation	Wake-up from SLEEP: – through interrupt – through WDT time-out
W	—	xxxx xxxx	uuuu uuuu	uuuu uuuu
INDF	00h	---- ----	---- ----	---- ----
TMR0	01h	xxxx xxxx	uuuu uuuu	uuuu uuuu
PCL	02h	0000h	0000h	PC + 1 ⁽²⁾
STATUS	03h	0001 1xxx	000q quuu ⁽³⁾	uuuq quuu ⁽³⁾
FSR	04h	xxxx xxxx	uuuu uuuu	uuuu uuuu
PORTA	05h	---x xxxx	---u uuuu	---u uuuu
PORTB	06h	xxxx xxxx	uuuu uuuu	uuuu uuuu
EEDATA	08h	xxxx xxxx	uuuu uuuu	uuuu uuuu
EEADR	09h	xxxx xxxx	uuuu uuuu	uuuu uuuu
PCLATH	0Ah	---0 0000	---0 0000	---u uuuu
INTCON	0Bh	0000 000x	0000 000u	uuuu uuuu ⁽¹⁾
INDF	80h	---- ----	---- ----	---- ----
OPTION_REG	81h	1111 1111	1111 1111	uuuu uuuu
PCL	82h	0000h	0000h	PC + 1
STATUS	83h	0001 1xxx	000q quuu ⁽³⁾	uuuq quuu ⁽³⁾
FSR	84h	xxxx xxxx	uuuu uuuu	uuuu uuuu
TRISA	85h	---1 1111	---1 1111	---u uuuu
TRISB	86h	1111 1111	1111 1111	uuuu uuuu
EECON1	88h	---0 x000	---0 q000	---0 uuuu
EECON2	89h	---- ----	---- ----	---- ----
PCLATH	8Ah	---0 0000	---0 0000	---u uuuu
INTCON	8Bh	0000 000x	0000 000u	uuuu uuuu ⁽¹⁾

Legend: u = unchanged, x = unknown, - = unimplemented bit read as '0', q = value depends on condition.

Note 1: One or more bits in INTCON will be affected (to cause wake-up).

2: When the wake-up is due to an interrupt and the GIE bit is set, the PC is loaded with the interrupt vector (0004h).

3: Table 8-3 lists the reset value for each specific condition.

8.4 Power-on Reset (POR)

A Power-on Reset pulse is generated on-chip when VDD rise is detected (in the range of 1.2V - 1.7V). To take advantage of the POR, just tie the $\overline{\text{MCLR}}$ pin directly (or through a resistor) to VDD. This will eliminate external RC components usually needed to create Power-on Reset. A minimum rise time for VDD must be met for this to operate properly. See Electrical Specifications for details.

When the device starts normal operation (exits the reset condition), device operating parameters (voltage, frequency, temperature, ...) must be met to ensure operation. If these conditions are not met, the device must be held in reset until the operating conditions are met.

For additional information, refer to Application Note AN607, *Power-up Trouble Shooting*.

The POR circuit does not produce an internal reset when VDD declines.

8.5 Power-up Timer (PWRT)

The Power-up Timer (PWRT) provides a fixed 72 ms nominal time-out (TPWRT) from POR (Figure 8-9, Figure 8-10, Figure 8-11 and Figure 8-12). The Power-up Timer operates on an internal RC oscillator. The chip is kept in reset as long as the PWRT is active. The PWRT delay allows the VDD to rise to an acceptable level (Possible exception shown in Figure 8-12).

A configuration bit, PWRTE, can enable/disable the PWRT (Figure 8-1).

The power-up time delay TPWRT will vary from chip to chip due to VDD, temperature, and process variation. See DC parameters for details.

8.6 Oscillator Start-up Timer (OST)

The Oscillator Start-up Timer (OST) provides a 1024 oscillator cycle delay (from OSC1 input) after the PWRT delay ends (Figure 8-9, Figure 8-10, Figure 8-11 and Figure 8-12). This ensures the crystal oscillator or resonator has started and stabilized.

The OST time-out (TOST) is invoked only for XT, LP and HS modes and only on Power-on Reset or wake-up from SLEEP.

When VDD rises very slowly, it is possible that the TPWRT time-out and TOST time-out will expire before VDD has reached its final value. In this case (Figure 8-12), an external power-on reset circuit may be necessary (Figure 8-8).

FIGURE 8-8: EXTERNAL POWER-ON RESET CIRCUIT (FOR SLOW VDD POWER-UP)

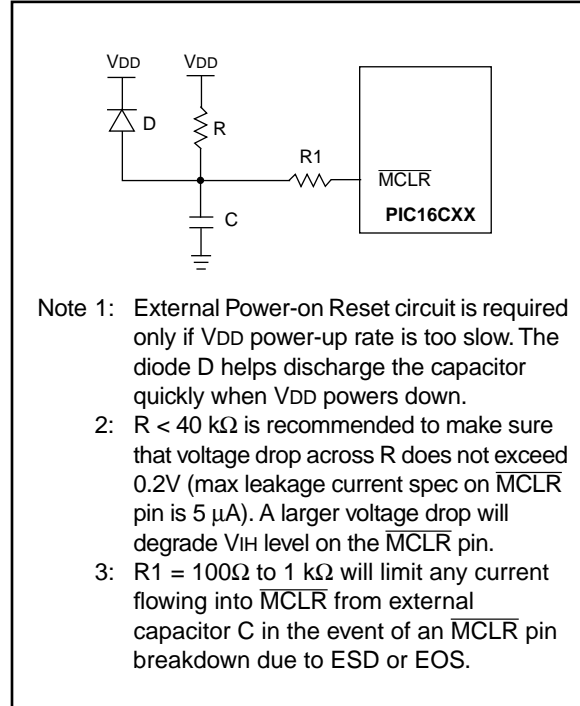

FIGURE 8-9: TIME-OUT SEQUENCE ON POWER-UP ($\overline{\text{MCLR}}$ NOT TIED TO V_{DD}): CASE 1

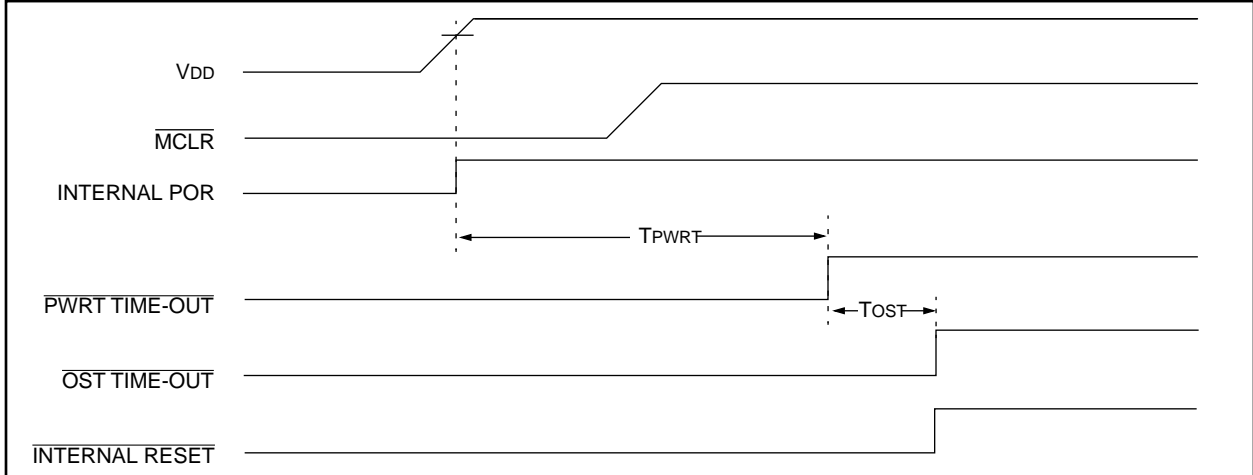
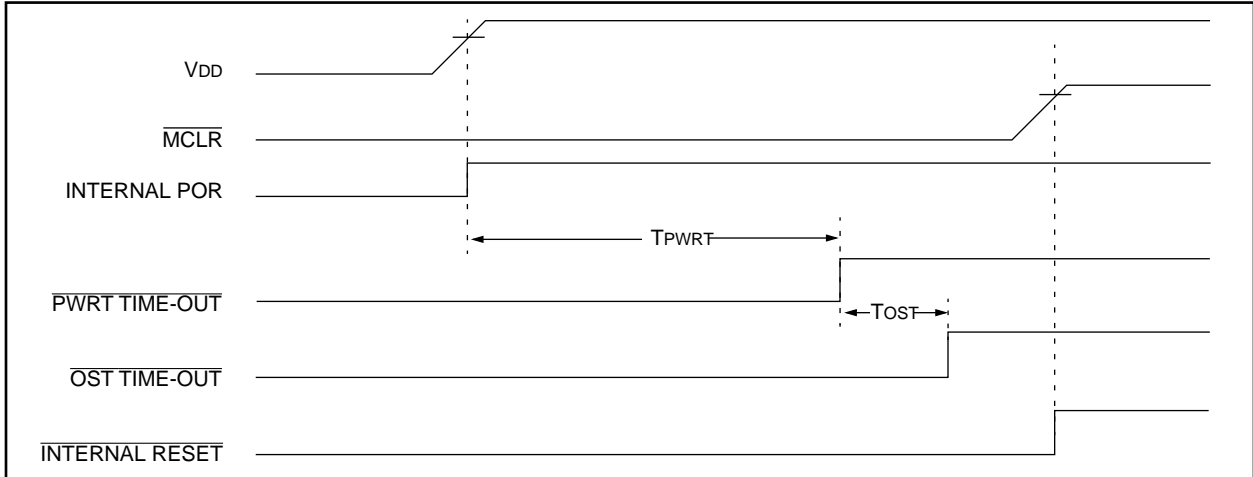

FIGURE 8-10: TIME-OUT SEQUENCE ON POWER-UP ($\overline{\text{MCLR}}$ NOT TIED TO V_{DD}): CASE 2



PIC16C84

FIGURE 8-11: TIME-OUT SEQUENCE ON POWER-UP ($\overline{\text{MCLR}}$ TIED TO V_{DD}): FAST V_{DD} RISE TIME

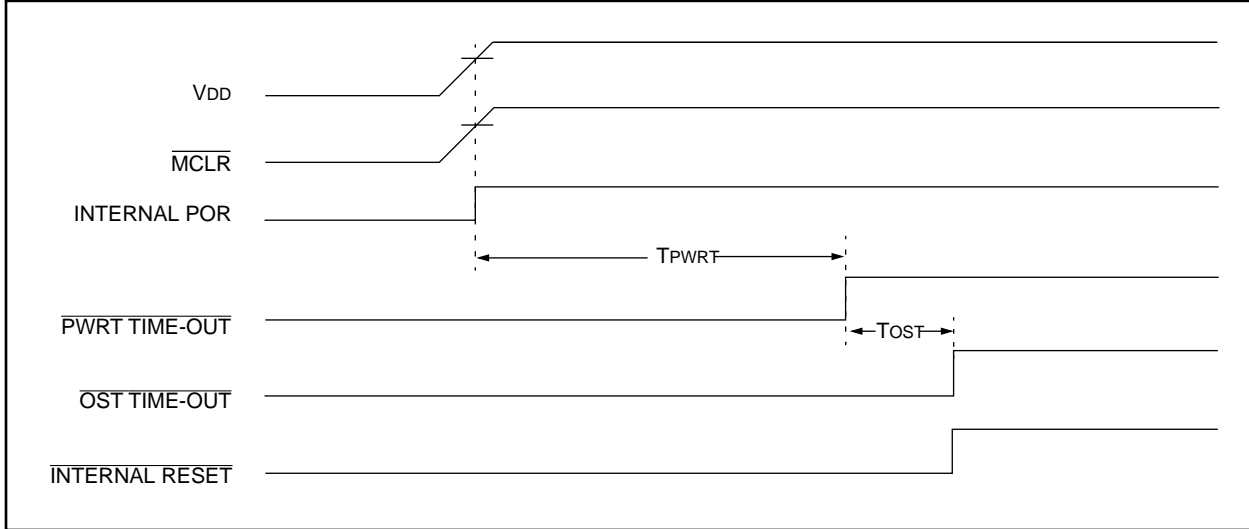
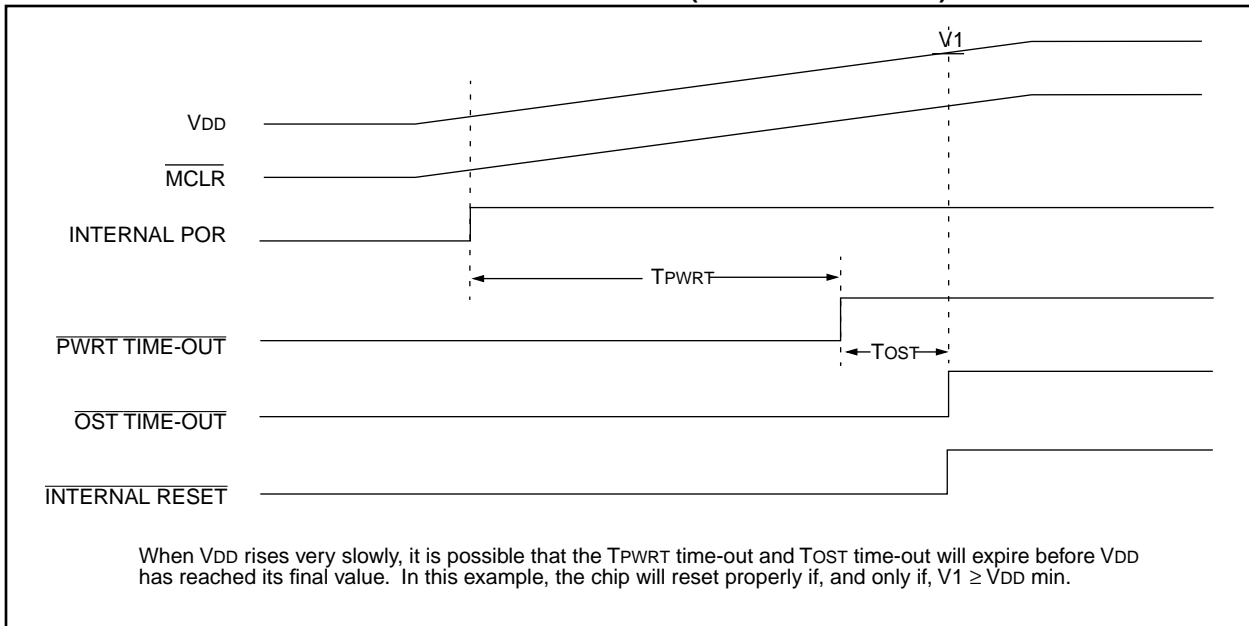

FIGURE 8-12: TIME-OUT SEQUENCE ON POWER-UP ($\overline{\text{MCLR}}$ TIED TO V_{DD}): SLOW V_{DD} RISE TIME



8.7 Time-out Sequence and Power Down Status Bits (\overline{TO} / \overline{PD})

On power-up (Figure 8-9, Figure 8-10, Figure 8-11 and Figure 8-12) the time-out sequence is as follows: First PWRT time-out is invoked after a POR has expired. Then the OST is activated. The total time-out will vary based on oscillator configuration and PWRTE configuration bit status. For example, in RC mode with the PWRT disabled, there will be no time-out at all.

TABLE 8-5 TIME-OUT IN VARIOUS SITUATIONS

Oscillator Configuration	Power-up		Wake-up from SLEEP
	PWRT Enabled	PWRT Disabled	
XT, HS, LP	72 ms + 1024Tosc	1024Tosc	1024Tosc
RC	72 ms	—	—

Since the time-outs occur from the POR reset pulse, if \overline{MCLR} is kept low long enough, the time-outs will expire. Then bringing \overline{MCLR} high, execution will begin immediately (Figure 8-9). This is useful for testing purposes or to synchronize more than one PIC16CXX device when operating in parallel.

Table 8-6 shows the significance of the \overline{TO} and \overline{PD} bits. Table 8-3 lists the reset conditions for some special registers, while Table 8-4 lists the reset conditions for all the registers.

TABLE 8-6 STATUS BITS AND THEIR SIGNIFICANCE

\overline{TO}	\overline{PD}	Condition
1	1	Power-on Reset
0	x	Illegal, \overline{TO} is set on POR
x	0	Illegal, \overline{PD} is set on POR
0	1	WDT Reset (during normal operation)
0	0	WDT Wake-up
1	1	\overline{MCLR} Reset during normal operation
1	0	\overline{MCLR} Reset during SLEEP or interrupt wake-up from SLEEP

8.8 Reset on Brown-Out

A brown-out is a condition where device power (V_{DD}) dips below its minimum value, but not to zero, and then recovers. The device should be reset in the event of a brown-out.

To reset PIC16C84 devices when a brown-out occurs, external brown-out protection circuits may be built, as shown in Figure 8-13 and Figure 8-14.

FIGURE 8-13: BROWN-OUT PROTECTION CIRCUIT 1

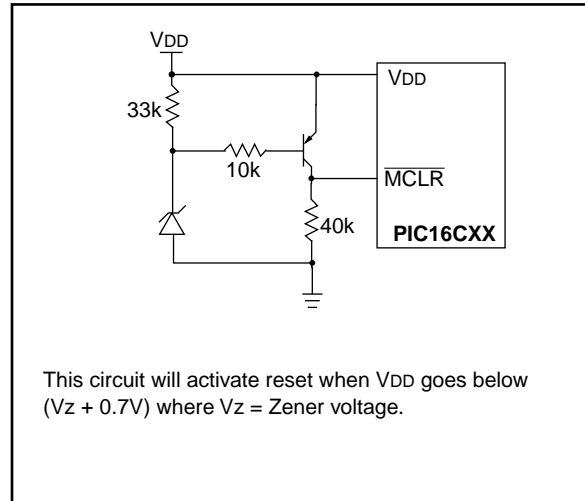
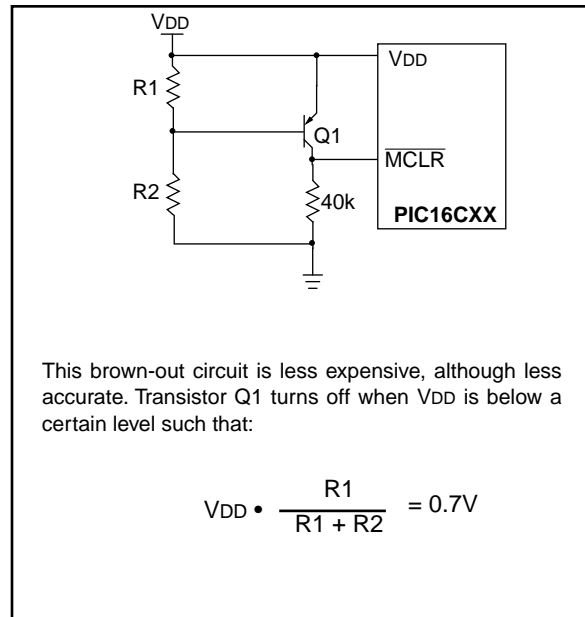

FIGURE 8-14: BROWN-OUT PROTECTION CIRCUIT 2



PIC16C84

8.9 Interrupts

The PIC16C84 has 4 sources of interrupt:

- External interrupt RB0/INT pin
- TMR0 overflow interrupt
- PORTB change interrupts (pins RB7:RB4)
- EEPROM write complete interrupt

The interrupt control register (INTCON) records individual interrupt requests in flag bits. It also contains the individual and global interrupt enable bits.

The global interrupt enable bit, GIE (INTCON<7>) enables (if set) all un-masked interrupts or disables (if cleared) all interrupts. Individual interrupts can be disabled through their corresponding enable bits in INTCON register. Bit GIE is cleared on reset.

The “return from interrupt” instruction, RETFIE, exits interrupt routine as well as sets the GIE bit, which re-enable interrupts.

The RB0/INT pin interrupt, the RB port change interrupt and the TMR0 overflow interrupt flags are contained in the INTCON register.

When an interrupt is responded to; the GIE bit is cleared to disable any further interrupt, the return address is pushed onto the stack and the PC is loaded with 0004h. For external interrupt events, such as the RB0/INT pin or PORTB change interrupt, the interrupt latency will be three to four instruction cycles. The exact latency depends when the interrupt event occurs (Figure 8-16). The latency is the same for both one and two cycle instructions. Once in the interrupt service routine the source(s) of the interrupt can be determined by polling the interrupt flag bits. The interrupt flag bit(s) must be cleared in software before re-enabling interrupts to avoid infinite interrupt requests.

Note 1: Individual interrupt flag bits are set regardless of the status of their corresponding mask bit or the GIE bit.

Note 2: If an interrupt occurs while the Global Interrupt Enable (GIE) bit is being cleared, the GIE bit may unintentionally be re-enabled by the user's Interrupt Service Routine (the RETFIE instruction). The events that would cause this to occur are:

1. An instruction clears the GIE bit while an interrupt is acknowledged
2. The program branches to the Interrupt vector and executes the Interrupt Service Routine.
3. The Interrupt Service Routine completes with the execution of the RETFIE instruction. This causes the GIE bit to be set (enables interrupts), and the program returns to the instruction after the one which was meant to disable interrupts.

The method to ensure that interrupts are globally disabled is:

1. Ensure that the GIE bit is cleared by the instruction, as shown in the following code:

```
LOOP  BCF    INTCON,GIE    ;Disable All
                                   ; Interrupts
      BTFSC  INTCON,GIE    ;All Interrupts
                                   ; Disabled?
      GOTO   LOOP         ;NO, try again
                                   ; Yes, continue
                                   ; with program
                                   ; flow
```

FIGURE 8-15: INTERRUPT LOGIC

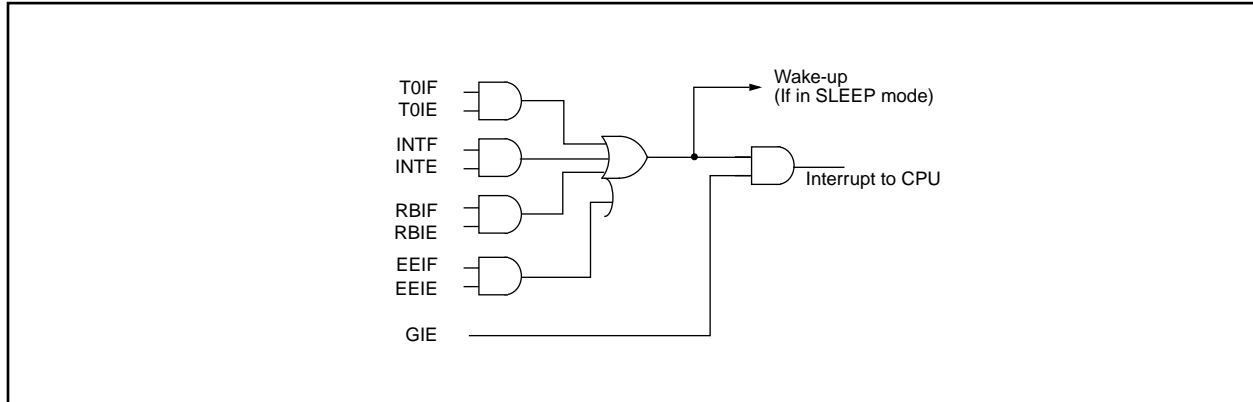
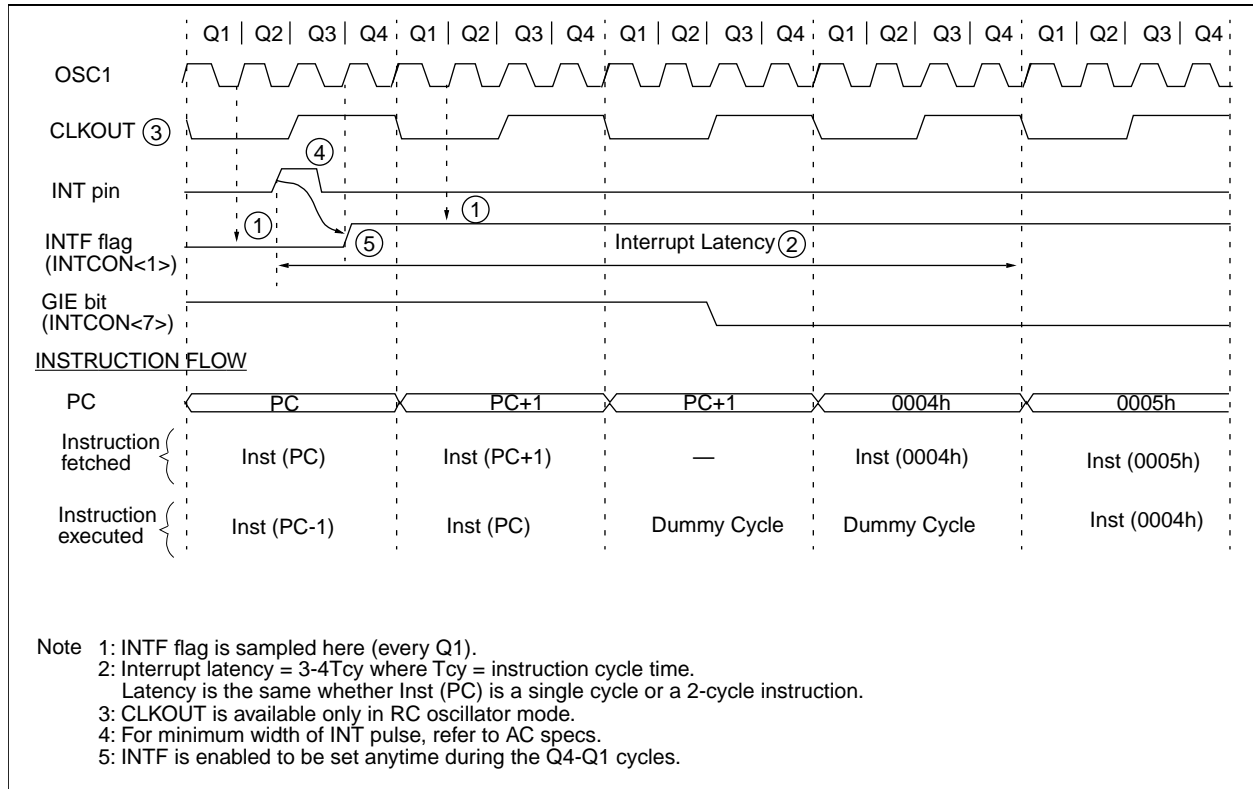

FIGURE 8-16: INT PIN INTERRUPT TIMING



8.9.1 INT INTERRUPT

External interrupt on RB0/INT pin is edge triggered: either rising if INTEDG bit (OPTION_REG<6>) is set, or falling, if INTEDG bit is clear. When a valid edge appears on the RB0/INT pin, the INTF bit (INTCON<1>) is set. This interrupt can be disabled by clearing control bit INTE (INTCON<4>). Flag bit INTF must be cleared in software via the interrupt service routine before re-enabling this interrupt. The INT interrupt can wake the processor from SLEEP (Section 8.12) only if the INTE bit was set prior to going into SLEEP. The status of the GIE bit decides whether the processor branches to the interrupt vector following wake-up.

8.9.2 TMR0 INTERRUPT

An overflow (FFh → 00h) in TMR0 will set flag bit T0IF (INTCON<2>). The interrupt can be enabled/disabled by setting/clearing enable bit T0IE (INTCON<5>) (Section 6.0).

8.9.3 PORT RB INTERRUPT

An input change on PORTB<7:4> sets flag bit RBIF (INTCON<0>). The interrupt can be enabled/disabled by setting/clearing enable bit RBIE (INTCON<3>) (Section 5.2).

Note 1: If a change on an I/O pin should occur when a read operation of PORTB is being executed (start of the Q2 cycle), the RBIF interrupt flag bit may not get set.

EXAMPLE 8-1: SAVING STATUS AND W REGISTERS IN RAM

```
PUSH  MOVWF  W_TEMP      ; Copy W to TEMP register,
      SWAPF  STATUS, W    ; Swap status to be saved into W
      MOVWF  STATUS_TEMP ; Save status to STATUS_TEMP register
ISR   :
      :                  ; Interrupt Service Routine
      :                  ; should configure Bank as required
      :
POP   SWAPF  STATUS_TEMP, W ; Swap nibbles in STATUS_TEMP register
      :                  ; and place result into W
      MOVWF  STATUS      ; Move W into STATUS register
      :                  ; (sets bank to original state)
      SWAPF  W_TEMP, F    ; Swap nibbles in W_TEMP and place result in W_TEMP
      SWAPF  W_TEMP, W    ; Swap nibbles in W_TEMP and place result into W
```

8.10 Context Saving During Interrupts

During an interrupt, only the return PC value is saved on the stack. Typically, users wish to save key register values during an interrupt (e.g., W register and STATUS register). This is implemented in software.

Example 8-1 stores and restores the STATUS and W register's values. The User defined registers, W_TEMP and STATUS_TEMP are the temporary storage locations for the W and STATUS registers values.

Example 8-1 does the following:

- a) Stores the W register.
- b) Stores the STATUS register in STATUS_TEMP.
- c) Executes the Interrupt Service Routine code.
- d) Restores the STATUS (and bank select bit) register.
- e) Restores the W register.

8.11 Watchdog Timer (WDT)

The Watchdog Timer is a free running on-chip RC oscillator which does not require any external components. This RC oscillator is separate from the RC oscillator of the OSC1/CLKIN pin. That means that the WDT will run even if the clock on the OSC1/CLKIN and OSC2/CLKOUT pins of the device has been stopped, for example, by execution of a SLEEP instruction. During normal operation a WDT time-out generates a device RESET. If the device is in SLEEP mode, a WDT Wake-up causes the device to wake-up and continue with normal operation. The WDT can be permanently disabled by programming configuration bit WDTE as a '0' (Section 8.1).

8.11.1 WDT PERIOD

The WDT has a nominal time-out period of 18 ms, (with no prescaler). The time-out periods vary with temperature, VDD and process variations from part to part (see DC specs). If longer time-out periods are desired, a prescaler with a division ratio of up to 1:128 can be assigned to the WDT under software control by writing to the OPTION_REG register. Thus, time-out periods up to 2.3 seconds can be realized.

The CLRWDT and SLEEP instructions clear the WDT and the postscaler (if assigned to the WDT) and prevent it from timing out and generating a device RESET condition.

The \overline{TO} bit in the STATUS register will be cleared upon a WDT time-out.

The \overline{TO} bit in the STATUS register will be cleared upon a WDT time-out.

8.11.2 WDT PROGRAMMING CONSIDERATIONS

It should also be taken into account that under worst case conditions (VDD = Min., Temperature = Max., max. WDT prescaler) it may take several seconds before a WDT time-out occurs.

FIGURE 8-17: WATCHDOG TIMER BLOCK DIAGRAM

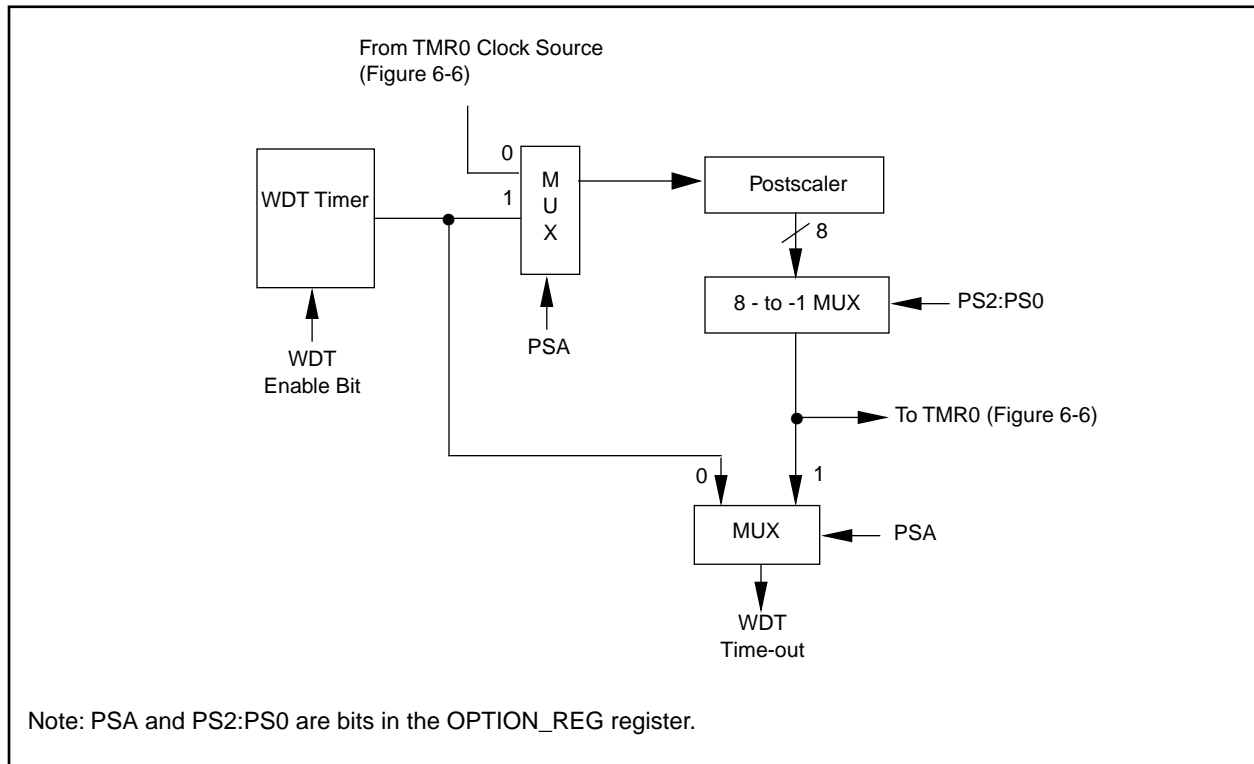

TABLE 8-7 SUMMARY OF REGISTERS ASSOCIATED WITH THE WATCHDOG TIMER

Address	Name	Bit 7	Bit 6	Bit 5	Bit 4	Bit 3	Bit 2	Bit 1	Bit 0	Value on Power-on Reset	Value on all other resets
2007h	Config. bits	—	—	—	CP	PWRTE	WDTE	FOSC1	FOSC0		
81h	OPTION_REG	RBP \overline{U}	INTEDG	TOCS	TOSE	PSA	PS2	PS1	PS0	1111 1111	1111 1111

Legend: x = unknown. Shaded cells are not used by the WDT.

8.12 Power-down Mode (SLEEP)

A device may be powered down (SLEEP) and later powered up (Wake-up from SLEEP).

8.12.1 SLEEP

The Power-down mode is entered by executing the SLEEP instruction.

If enabled, the Watchdog Timer is cleared (but keeps running), the PD bit (STATUS<3>) is cleared, the TO bit (STATUS<4>) is set, and the oscillator driver is turned off. The I/O ports maintain the status they had before the SLEEP instruction was executed (driving high, low, or hi-impedance).

For the lowest current consumption in SLEEP mode, place all I/O pins at either at VDD or VSS, with no external circuitry drawing current from the I/O pins, and disable external clocks. I/O pins that are hi-impedance inputs should be pulled high or low externally to avoid switching currents caused by floating inputs. The TOCKI input should also be at VDD or VSS. The contribution from on-chip pull-ups on PORTB should be considered.

The MCLR pin must be at a logic high level (VIHMC).

It should be noted that a RESET generated by a WDT time-out does not drive the MCLR pin low.

8.12.2 WAKE-UP FROM SLEEP

The device can wake-up from SLEEP through one of the following events:

1. External reset input on MCLR pin.
2. WDT Wake-up (if WDT was enabled).
3. Interrupt from RB0/INT pin, RB port change, or data EEPROM write complete.

Peripherals cannot generate interrupts during SLEEP, since no on-chip Q clocks are present.

The first event (MCLR reset) will cause a device reset. The two latter events are considered a continuation of program execution. The TO and PD bits can be used to determine the cause of a device reset. The PD bit, which is set on power-up, is cleared when SLEEP is invoked. The TO bit is cleared if a WDT time-out occurred (and caused wake-up).

While the SLEEP instruction is being executed, the next instruction (PC + 1) is pre-fetched. For the device to wake-up through an interrupt event, the corresponding interrupt enable bit must be set (enabled). Wake-up occurs regardless of the state of the GIE bit. If the GIE bit is clear (disabled), the device continues execution at the instruction after the SLEEP instruction. If the GIE bit is set (enabled), the device executes the instruction after the SLEEP instruction and then branches to the interrupt address (0004h). In cases where the execution of the instruction following SLEEP is not desirable, the user should have a NOP after the SLEEP instruction.

FIGURE 8-18: WAKE-UP FROM SLEEP THROUGH INTERRUPT

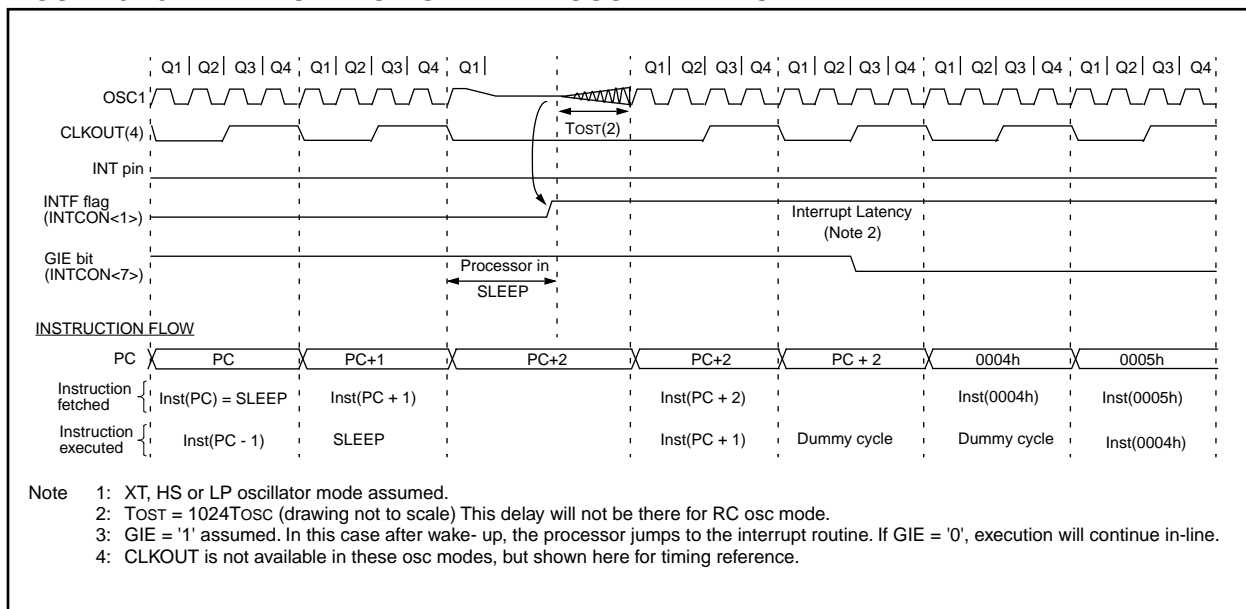

8.12.3 WAKE-UP USING INTERRUPTS

When global interrupts are disabled (GIE cleared) and any interrupt source has both its interrupt enable bit and interrupt flag bit set, one of the following will occur:

- If the interrupt occurs **before** the execution of a SLEEP instruction, the SLEEP instruction will complete as a NOP. Therefore, the WDT and WDT postscaler will not be cleared, the \overline{TO} bit will not be set and \overline{PD} bits will not be cleared.
- If the interrupt occurs **during or after** the execution of a SLEEP instruction, the device will immediately wake up from sleep. The SLEEP instruction will be completely executed before the wake-up. Therefore, the WDT and WDT postscaler will be cleared, the \overline{TO} bit will be set and the \overline{PD} bit will be cleared.

Even if the flag bits were checked before executing a SLEEP instruction, it may be possible for flag bits to become set before the SLEEP instruction completes. To determine whether a SLEEP instruction executed, test the \overline{PD} bit. If the \overline{PD} bit is set, the SLEEP instruction was executed as a NOP.

To ensure that the WDT is cleared, a CLRWDT instruction should be executed before a SLEEP instruction.

8.13 Program Verification/Code Protection

If the code protection bit(s) have not been programmed, the on-chip program memory can be read out for verification purposes.

Note: Microchip does not recommend code protecting windowed devices..

8.14 ID Locations

Four memory locations (2000h - 2003h) are designated as ID locations to store checksum or other code identification numbers. These locations are not accessible during normal execution but are readable and writable only during program/verify. Only the 4 least significant bits of ID location are usable.

For ROM devices, these values are submitted along with the ROM code.

8.15 In-Circuit Serial Programming

PIC16C84 microcontrollers can be serially programmed while in the end application circuit. This is simply done with two lines for clock and data, and three other lines for power, ground, and the programming voltage. Customers can manufacture boards with unprogrammed devices, and then program the microcontroller just before shipping the product, allowing the most recent firmware or custom firmware to be programmed.

The device is placed into a program/verify mode by holding the RB6 and RB7 pins low, while raising the \overline{MCLR} pin from V_{IL} to V_{IH} (see *PIC16C84 EEPROM Memory Programming Specification* (DS30189)). RB6 becomes the programming clock and RB7 becomes the programming data. Both RB6 and RB7 are Schmitt inputs in this mode.

After reset, to place the device into programming/verify mode, the program counter (PC) points to location 00h. A 6-bit command is then supplied to the device, 14-bits of program data is then supplied to or from the device, using load or read-type instructions. For complete details of serial programming, please refer to the *In-Circuit Serial Programming Guide* (DS30277).

For ROM devices, both the program memory and Data EEPROM memory may be read, but only the Data EEPROM memory may be programmed.

FIGURE 8-19: TYPICAL IN-SYSTEM SERIAL PROGRAMMING CONNECTION

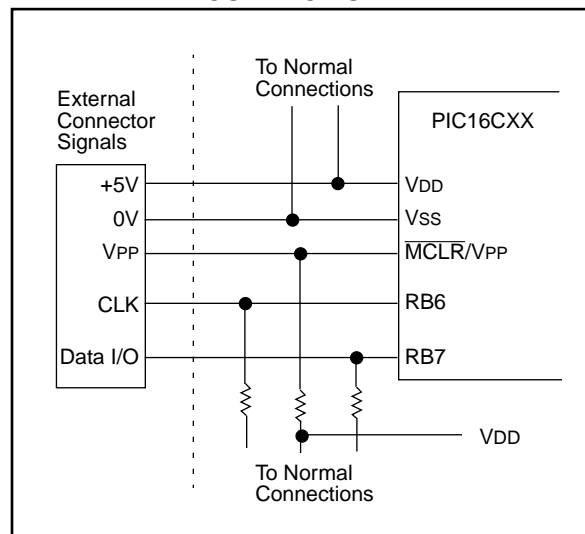

PIC16C84

NOTES:

9.0 INSTRUCTION SET SUMMARY

Each PIC16CXX instruction is a 14-bit word divided into an OPCODE which specifies the instruction type and one or more operands which further specify the operation of the instruction. The PIC16CXX instruction set summary in Table 9-2 lists **byte-oriented**, **bit-oriented**, and **literal and control** operations. Table 9-1 shows the opcode field descriptions.

For **byte-oriented** instructions, 'f' represents a file register designator and 'd' represents a destination designator. The file register designator specifies which file register is to be used by the instruction.

The destination designator specifies where the result of the operation is to be placed. If 'd' is zero, the result is placed in the W register. If 'd' is one, the result is placed in the file register specified in the instruction.

For **bit-oriented** instructions, 'b' represents a bit field designator which selects the number of the bit affected by the operation, while 'f' represents the number of the file in which the bit is located.

For **literal and control** operations, 'k' represents an eight or eleven bit constant or literal value.

TABLE 9-1 OPCODE FIELD DESCRIPTIONS

Field	Description
f	Register file address (0x00 to 0x7F)
w	Working register (accumulator)
b	Bit address within an 8-bit file register
k	Literal field, constant data or label
x	Don't care location (= 0 or 1) The assembler will generate code with x = 0. It is the recommended form of use for compatibility with all Microchip software tools.
d	Destination select; d = 0: store result in W, d = 1: store result in file register f. Default is d = 1
label	Label name
TOS	Top of Stack
PC	Program Counter
PCLATH	Program Counter High Latch
GIE	Global Interrupt Enable bit
WDT	Watchdog Timer/Counter
T \bar{O}	Time-out bit
P \bar{D}	Power-down bit
dest	Destination either the W register or the specified register file location
[]	Options
()	Contents
→	Assigned to
< >	Register bit field
∈	In the set of
<i>italics</i>	User defined term (font is courier)

The instruction set is highly orthogonal and is grouped into three basic categories:

- **Byte-oriented** operations
- **Bit-oriented** operations
- **Literal and control** operations

All instructions are executed within one single instruction cycle, unless a conditional test is true or the program counter is changed as a result of an instruction. In this case, the execution takes two instruction cycles with the second cycle executed as a NOP. One instruction cycle consists of four oscillator periods. Thus, for an oscillator frequency of 4 MHz, the normal instruction execution time is 1 μ s. If a conditional test is true or the program counter is changed as a result of an instruction, the instruction execution time is 2 μ s.

Table 9-2 lists the instructions recognized by the MPASM assembler.

Figure 9-1 shows the general formats that the instructions can have.

Note: To maintain upward compatibility with future PIC16CXX products, do not use the OPTION and TRIS instructions.

All examples use the following format to represent a hexadecimal number:

0xhh

where h signifies a hexadecimal digit.

FIGURE 9-1: GENERAL FORMAT FOR INSTRUCTIONS

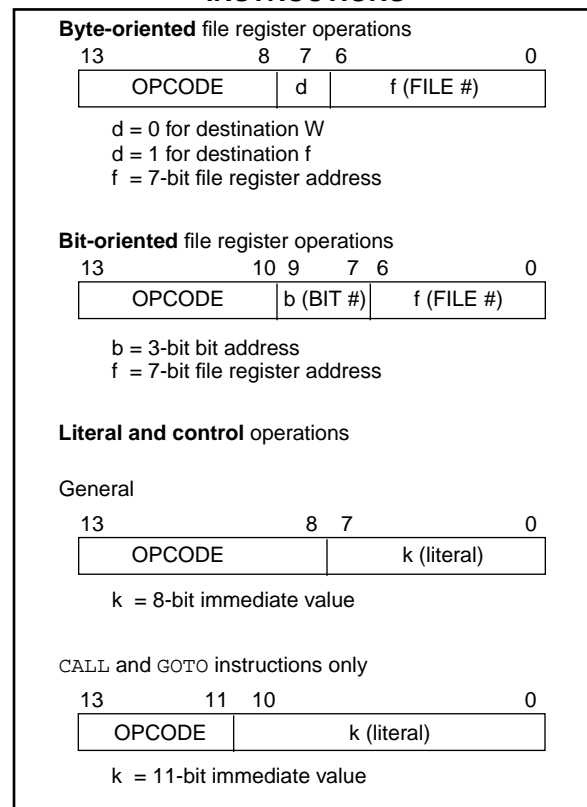

PIC16C84

TABLE 9-2 PIC16CXX INSTRUCTION SET

Mnemonic, Operands	Description	Cycles	14-Bit Opcode				Status Affected	Notes
			MSb		LSb			
BYTE-ORIENTED FILE REGISTER OPERATIONS								
ADDWF f, d	Add W and f	1	00	0111	dfff	ffff	C,DC,Z	1,2
ANDWF f, d	AND W with f	1	00	0101	dfff	ffff	Z	1,2
CLRF f	Clear f	1	00	0001	1fff	ffff	Z	2
CLRWF -	Clear W	1	00	0001	0xxx	xxxx	Z	
COMF f, d	Complement f	1	00	1001	dfff	ffff	Z	1,2
DECF f, d	Decrement f	1	00	0011	dfff	ffff	Z	1,2
DECFSZ f, d	Decrement f, Skip if 0	1(2)	00	1011	dfff	ffff		1,2,3
INCF f, d	Increment f	1	00	1010	dfff	ffff	Z	1,2
INCFSZ f, d	Increment f, Skip if 0	1(2)	00	1111	dfff	ffff		1,2,3
IORWF f, d	Inclusive OR W with f	1	00	0100	dfff	ffff	Z	1,2
MOVF f, d	Move f	1	00	1000	dfff	ffff	Z	1,2
MOVWF f	Move W to f	1	00	0000	1fff	ffff		
NOP -	No Operation	1	00	0000	0xx0	0000		
RLF f, d	Rotate Left f through Carry	1	00	1101	dfff	ffff	C	1,2
RRF f, d	Rotate Right f through Carry	1	00	1100	dfff	ffff	C	1,2
SUBWF f, d	Subtract W from f	1	00	0010	dfff	ffff	C,DC,Z	1,2
SWAPF f, d	Swap nibbles in f	1	00	1110	dfff	ffff		1,2
XORWF f, d	Exclusive OR W with f	1	00	0110	dfff	ffff	Z	1,2
BIT-ORIENTED FILE REGISTER OPERATIONS								
BCF f, b	Bit Clear f	1	01	00bb	bfff	ffff		1,2
BSF f, b	Bit Set f	1	01	01bb	bfff	ffff		1,2
BTFSC f, b	Bit Test f, Skip if Clear	1 (2)	01	10bb	bfff	ffff		3
BTFSS f, b	Bit Test f, Skip if Set	1 (2)	01	11bb	bfff	ffff		3
LITERAL AND CONTROL OPERATIONS								
ADDLW k	Add literal and W	1	11	111x	kkkk	kkkk	C,DC,Z	
ANDLW k	AND literal with W	1	11	1001	kkkk	kkkk	Z	
CALL k	Call subroutine	2	10	0kkk	kkkk	kkkk		
CLRWDT -	Clear Watchdog Timer	1	00	0000	0110	0100	$\overline{TO}, \overline{PD}$	
GOTO k	Go to address	2	10	1kkk	kkkk	kkkk		
IORLW k	Inclusive OR literal with W	1	11	1000	kkkk	kkkk	Z	
MOVLW k	Move literal to W	1	11	00xx	kkkk	kkkk		
RETFIE -	Return from interrupt	2	00	0000	0000	1001		
RETLW k	Return with literal in W	2	11	01xx	kkkk	kkkk		
RETURN -	Return from Subroutine	2	00	0000	0000	1000		
SLEEP -	Go into standby mode	1	00	0000	0110	0011	$\overline{TO}, \overline{PD}$	
SUBLW k	Subtract W from literal	1	11	110x	kkkk	kkkk	C,DC,Z	
XORLW k	Exclusive OR literal with W	1	11	1010	kkkk	kkkk	Z	

- Note 1:** When an I/O register is modified as a function of itself (e.g., `MOVF PORTB, 1`), the value used will be that value present on the pins themselves. For example, if the data latch is '1' for a pin configured as input and is driven low by an external device, the data will be written back with a '0'.
- 2:** If this instruction is executed on the TMR0 register (and, where applicable, d = 1), the prescaler will be cleared if assigned to the Timer0 Module.
- 3:** If Program Counter (PC) is modified or a conditional test is true, the instruction requires two cycles. The second cycle is executed as a NOP.

9.1 Instruction Descriptions

ADDLW	Add Literal and W			
Syntax:	[label] ADDLW k			
Operands:	0 ≤ k ≤ 255			
Operation:	(W) + k → (W)			
Status Affected:	C, DC, Z			
Encoding:	11	111x	kkkk	kkkk
Description:	The contents of the W register are added to the eight bit literal 'k' and the result is placed in the W register.			
Words:	1			
Cycles:	1			
Q Cycle Activity:	Q1	Q2	Q3	Q4
	Decode	Read literal 'k'	Process data	Write to W

Example: ADDLW 0x15

Before Instruction
W = 0x10

After Instruction
W = 0x25

ANDLW	AND Literal with W			
Syntax:	[label] ANDLW k			
Operands:	0 ≤ k ≤ 255			
Operation:	(W) .AND. (k) → (W)			
Status Affected:	Z			
Encoding:	11	1001	kkkk	kkkk
Description:	The contents of W register are AND'ed with the eight bit literal 'k'. The result is placed in the W register.			
Words:	1			
Cycles:	1			
Q Cycle Activity:	Q1	Q2	Q3	Q4
	Decode	Read literal "k"	Process data	Write to W

Example ANDLW 0x5F

Before Instruction
W = 0xA3

After Instruction
W = 0x03

ADDWF	Add W and f			
Syntax:	[label] ADDWF f,d			
Operands:	0 ≤ f ≤ 127 d ∈ [0,1]			
Operation:	(W) + (f) → (destination)			
Status Affected:	C, DC, Z			
Encoding:	00	0111	dfff	ffff
Description:	Add the contents of the W register with register 'f'. If 'd' is 0 the result is stored in the W register. If 'd' is 1 the result is stored back in register 'f'.			
Words:	1			
Cycles:	1			
Q Cycle Activity:	Q1	Q2	Q3	Q4
	Decode	Read register 'f'	Process data	Write to destination

Example ADDWF FSR, 0

Before Instruction
W = 0x17
FSR = 0xC2

After Instruction
W = 0xD9
FSR = 0xC2

ANDWF	AND W with f			
Syntax:	[label] ANDWF f,d			
Operands:	0 ≤ f ≤ 127 d ∈ [0,1]			
Operation:	(W) .AND. (f) → (destination)			
Status Affected:	Z			
Encoding:	00	0101	dfff	ffff
Description:	AND the W register with register 'f'. If 'd' is 0 the result is stored in the W register. If 'd' is 1 the result is stored back in register 'f'.			
Words:	1			
Cycles:	1			
Q Cycle Activity:	Q1	Q2	Q3	Q4
	Decode	Read register 'f'	Process data	Write to destination

Example ANDWF FSR, 1

Before Instruction
W = 0x17
FSR = 0xC2

After Instruction
W = 0x17
FSR = 0x02

PIC16C84

BCF	Bit Clear f								
Syntax:	[label] BCF f,b								
Operands:	0 ≤ f ≤ 127 0 ≤ b ≤ 7								
Operation:	0 → (f)								
Status Affected:	None								
Encoding:	<table border="1"> <tr> <td>01</td> <td>00bb</td> <td>bfff</td> <td>ffff</td> </tr> </table>	01	00bb	bfff	ffff				
01	00bb	bfff	ffff						
Description:	Bit 'b' in register 'f' is cleared.								
Words:	1								
Cycles:	1								
Q Cycle Activity:	<table border="1"> <thead> <tr> <th>Q1</th> <th>Q2</th> <th>Q3</th> <th>Q4</th> </tr> </thead> <tbody> <tr> <td>Decode</td> <td>Read register 'f'</td> <td>Process data</td> <td>Write register 'f'</td> </tr> </tbody> </table>	Q1	Q2	Q3	Q4	Decode	Read register 'f'	Process data	Write register 'f'
Q1	Q2	Q3	Q4						
Decode	Read register 'f'	Process data	Write register 'f'						

Example

```

BCF    FLAG_REG, 7

Before Instruction
      FLAG_REG = 0xC7
After Instruction
      FLAG_REG = 0x47
  
```

BSF	Bit Set f								
Syntax:	[label] BSF f,b								
Operands:	0 ≤ f ≤ 127 0 ≤ b ≤ 7								
Operation:	1 → (f)								
Status Affected:	None								
Encoding:	<table border="1"> <tr> <td>01</td> <td>01bb</td> <td>bfff</td> <td>ffff</td> </tr> </table>	01	01bb	bfff	ffff				
01	01bb	bfff	ffff						
Description:	Bit 'b' in register 'f' is set.								
Words:	1								
Cycles:	1								
Q Cycle Activity:	<table border="1"> <thead> <tr> <th>Q1</th> <th>Q2</th> <th>Q3</th> <th>Q4</th> </tr> </thead> <tbody> <tr> <td>Decode</td> <td>Read register 'f'</td> <td>Process data</td> <td>Write register 'f'</td> </tr> </tbody> </table>	Q1	Q2	Q3	Q4	Decode	Read register 'f'	Process data	Write register 'f'
Q1	Q2	Q3	Q4						
Decode	Read register 'f'	Process data	Write register 'f'						

Example

```

BSF    FLAG_REG, 7

Before Instruction
      FLAG_REG = 0x0A
After Instruction
      FLAG_REG = 0x8A
  
```

BTFSC	Bit Test, Skip if Clear								
Syntax:	[label] BTFSC f,b								
Operands:	0 ≤ f ≤ 127 0 ≤ b ≤ 7								
Operation:	skip if (f) = 0								
Status Affected:	None								
Encoding:	<table border="1"> <tr> <td>01</td> <td>10bb</td> <td>bfff</td> <td>ffff</td> </tr> </table>	01	10bb	bfff	ffff				
01	10bb	bfff	ffff						
Description:	If bit 'b' in register 'f' is '1' then the next instruction is executed. If bit 'b', in register 'f', is '0' then the next instruction is discarded, and a NOP is executed instead, making this a 2TCY instruction.								
Words:	1								
Cycles:	1(2)								
Q Cycle Activity:	<table border="1"> <thead> <tr> <th>Q1</th> <th>Q2</th> <th>Q3</th> <th>Q4</th> </tr> </thead> <tbody> <tr> <td>Decode</td> <td>Read register 'f'</td> <td>Process data</td> <td>No-Operation</td> </tr> </tbody> </table>	Q1	Q2	Q3	Q4	Decode	Read register 'f'	Process data	No-Operation
Q1	Q2	Q3	Q4						
Decode	Read register 'f'	Process data	No-Operation						

If Skip: (2nd Cycle)

Q1	Q2	Q3	Q4
No-Operation	No-Operation	No-Operation	No-Operation

Example

```

HERE   BTFSC  FLAG, 1
FALSE  GOTO   PROCESS_CODE
TRUE   :
      :
      :
  
```

Before Instruction
PC = address HERE

After Instruction
if FLAG<1> = 0,
PC = address TRUE
if FLAG<1> = 1,
PC = address FALSE

BTFSS Bit Test f, Skip if Set

Syntax: `[label] BTFSS f,b`

Operands: $0 \leq f \leq 127$
 $0 \leq b < 7$

Operation: skip if $(f \langle b \rangle) = 1$

Status Affected: None

Encoding:

01	11bb	bfff	ffff
----	------	------	------

Description: If bit 'b' in register 'f' is '0' then the next instruction is executed. If bit 'b' is '1', then the next instruction is discarded and a NOP is executed instead, making this a 2TCY instruction.

Words: 1

Cycles: 1(2)

Q Cycle Activity:

	Q1	Q2	Q3	Q4
	Decode	Read register 'f'	Process data	No-Operation

If Skip: (2nd Cycle)

	Q1	Q2	Q3	Q4
	No-Operation	No-Operation	No-Operation	No-Operation

Example

```

HERE   BTFSC  FLAG,1
FALSE  GOTO   PROCESS_CODE
TRUE   •
        •
        •
    
```

Before Instruction
PC = address HERE

After Instruction
if FLAG<1> = 0,
PC = address FALSE
if FLAG<1> = 1,
PC = address TRUE

CALL Call Subroutine

Syntax: `[label] CALL k`

Operands: $0 \leq k \leq 2047$

Operation: $(PC)+1 \rightarrow TOS$,
 $k \rightarrow PC \langle 10:0 \rangle$,
 $(PCLATH \langle 4:3 \rangle) \rightarrow PC \langle 12:11 \rangle$

Status Affected: None

Encoding:

10	0kkk	kkkk	kkkk
----	------	------	------

Description: Call Subroutine. First, return address (PC+1) is pushed onto the stack. The eleven bit immediate address is loaded into PC bits <10:0>. The upper bits of the PC are loaded from PCLATH. CALL is a two cycle instruction.

Words: 1

Cycles: 2

Q Cycle Activity:

	Q1	Q2	Q3	Q4
1st Cycle	Decode	Read literal 'k', Push PC to Stack	Process data	Write to PC
2nd Cycle	No-Operation	No-Operation	No-Operation	No-Operation

Example

```

HERE   CALL   THERE
    
```

Before Instruction
PC = Address HERE

After Instruction
PC = Address THERE
TOS = Address HERE+1

PIC16C84

CLRF Clear f

Syntax: `[label] CLRF f`

Operands: $0 \leq f \leq 127$

Operation: $00h \rightarrow (f)$
 $1 \rightarrow Z$

Status Affected: Z

Encoding:

00	0001	1fff	ffff
----	------	------	------

Description: The contents of register 'f' are cleared and the Z bit is set.

Words: 1

Cycles: 1

Q Cycle Activity:

Q1	Q2	Q3	Q4
Decode	Read register 'f'	Process data	Write register 'f'

Example

```

CLRF    FLAG_REG

Before Instruction
FLAG_REG = 0x5A
After Instruction
FLAG_REG = 0x00
Z        = 1
    
```

CLRW Clear W

Syntax: `[label] CLRW`

Operands: None

Operation: $00h \rightarrow (W)$
 $1 \rightarrow Z$

Status Affected: Z

Encoding:

00	0001	0xxx	xxxx
----	------	------	------

Description: W register is cleared. Zero bit (Z) is set.

Words: 1

Cycles: 1

Q Cycle Activity:

Q1	Q2	Q3	Q4
Decode	No-Operation	Process data	Write to W

Example

```

CLRW

Before Instruction
W = 0x5A
After Instruction
W = 0x00
Z = 1
    
```

CLRWDT Clear Watchdog Timer

Syntax: `[label] CLRWDT`

Operands: None

Operation: $00h \rightarrow$ WDT
 $0 \rightarrow$ WDT prescaler,
 $1 \rightarrow \overline{TO}$
 $1 \rightarrow \overline{PD}$

Status Affected: \overline{TO} , \overline{PD}

Encoding:

00	0000	0110	0100
----	------	------	------

Description: CLRWDT instruction resets the Watchdog Timer. It also resets the prescaler of the WDT. Status bits \overline{TO} and \overline{PD} are set.

Words: 1

Cycles: 1

Q Cycle Activity:

Q1	Q2	Q3	Q4
Decode	No-Operation	Process data	Clear WDT Counter

Example

```

CLRWDT

Before Instruction
WDT counter = ?
After Instruction
WDT counter = 0x00
WDT prescaler = 0
 $\overline{TO}$  = 1
 $\overline{PD}$  = 1
    
```

COMF Complement f

Syntax: [label] COMF f,d

Operands: $0 \leq f \leq 127$
 $d \in [0,1]$

Operation: $(\bar{f}) \rightarrow (\text{destination})$

Status Affected: Z

Encoding:

00	1001	dfff	ffff
----	------	------	------

Description: The contents of register 'f' are complemented. If 'd' is 0 the result is stored in W. If 'd' is 1 the result is stored back in register 'f'.

Words: 1

Cycles: 1

Q Cycle Activity:

Q1	Q2	Q3	Q4
Decode	Read register 'f'	Process data	Write to destination

Example

```

COMF    REG1, 0
Before Instruction
    REG1 = 0x13
After Instruction
    REG1 = 0x13
    W    = 0xEC
    
```

DECF Decrement f

Syntax: [label] DECF f,d

Operands: $0 \leq f \leq 127$
 $d \in [0,1]$

Operation: $(f) - 1 \rightarrow (\text{destination})$

Status Affected: Z

Encoding:

00	0011	dfff	ffff
----	------	------	------

Description: Decrement register 'f'. If 'd' is 0 the result is stored in the W register. If 'd' is 1 the result is stored back in register 'f'.

Words: 1

Cycles: 1

Q Cycle Activity:

Q1	Q2	Q3	Q4
Decode	Read register 'f'	Process data	Write to destination

Example

```

DECF    CNT, 1
Before Instruction
    CNT = 0x01
    Z   = 0
After Instruction
    CNT = 0x00
    Z   = 1
    
```

DECFSZ Decrement f, Skip if 0

Syntax: [label] DECFSZ f,d

Operands: $0 \leq f \leq 127$
 $d \in [0,1]$

Operation: $(f) - 1 \rightarrow (\text{destination});$
skip if result = 0

Status Affected: None

Encoding:

00	1011	dfff	ffff
----	------	------	------

Description: The contents of register 'f' are decremented. If 'd' is 0 the result is placed in the W register. If 'd' is 1 the result is placed back in register 'f'. If the result is 1, the next instruction, is executed. If the result is 0, then a NOP is executed instead making it a 2Tcy instruction.

Words: 1

Cycles: 1(2)

Q Cycle Activity:

Q1	Q2	Q3	Q4
Decode	Read register 'f'	Process data	Write to destination

If Skip: (2nd Cycle)

Q1	Q2	Q3	Q4
No-Operation	No-Operation	No-Operation	No-Operation

Example

```

HERE    DECFSZ    CNT, 1
        GOTO     LOOP
CONTINUE
        .
        .
        .
Before Instruction
    PC = address HERE
After Instruction
    CNT = CNT - 1
    if CNT = 0,
    PC = address CONTINUE
    if CNT ≠ 0,
    PC = address HERE+1
    
```

PIC16C84

GOTO Unconditional Branch

Syntax: [*label*] GOTO *k*

Operands: $0 \leq k \leq 2047$

Operation: $k \rightarrow PC<10:0>$
 $PCLATH<4:3> \rightarrow PC<12:11>$

Status Affected: None

Encoding:

10	1kkk	kkkk	kkkk
----	------	------	------

Description: GOTO is an unconditional branch. The eleven bit immediate value is loaded into PC bits <10:0>. The upper bits of PC are loaded from PCLATH<4:3>. GOTO is a two cycle instruction.

Words: 1

Cycles: 2

Q Cycle Activity:

Q1	Q2	Q3	Q4
----	----	----	----

1st Cycle	Decode	Read literal 'k'	Process data	Write to PC
2nd Cycle	No-Operat ion	No-Operat ion	No-Opera tion	No-Operat ion

Example `GOTO THERE`
 After Instruction
 PC = Address THERE

INCF Increment f

Syntax: [*label*] INCF *f*,*d*

Operands: $0 \leq f \leq 127$
 $d \in [0,1]$

Operation: $(f) + 1 \rightarrow (\text{destination})$

Status Affected: Z

Encoding:

00	1010	dfff	ffff
----	------	------	------

Description: The contents of register 'f' are incremented. If 'd' is 0 the result is placed in the W register. If 'd' is 1 the result is placed back in register 'f'.

Words: 1

Cycles: 1

Q Cycle Activity:

Q1	Q2	Q3	Q4
----	----	----	----

Decode	Read register f	Process data	Write to destination
--------	-----------------------	-----------------	-------------------------

Example `INCF CNT, 1`
 Before Instruction
 CNT = 0xFF
 Z = 0
 After Instruction
 CNT = 0x00
 Z = 1

INCFSZ Increment f, Skip if 0

Syntax: [label] INCFSZ f,d

Operands: $0 \leq f \leq 127$
 $d \in [0,1]$

Operation: $(f) + 1 \rightarrow (\text{destination})$,
 skip if result = 0

Status Affected: None

Encoding:

00	1111	dfff	ffff
----	------	------	------

Description: The contents of register 'f' are incremented. If 'd' is 0 the result is placed in the W register. If 'd' is 1 the result is placed back in register 'f'. If the result is 1, the next instruction is executed. If the result is 0, a NOP is executed instead making it a 2TCY instruction.

Words: 1

Cycles: 1(2)

Q Cycle Activity:

Q1	Q2	Q3	Q4
Decode	Read register 'f'	Process data	Write to destination

If Skip: (2nd Cycle)

Q1	Q2	Q3	Q4
No-Operation	No-Operation	No-Operation	No-Operation

Example

```
HERE      INCFSZ      CNT, 1
            GOTO      LOOP
CONTINUE •
            •
            •
```

Before Instruction
 PC = address HERE
 After Instruction
 CNT = CNT + 1
 if CNT= 0,
 PC = address CONTINUE
 if CNT≠ 0,
 PC = address HERE +1

IORLW Inclusive OR Literal with W

Syntax: [label] IORLW k

Operands: $0 \leq k \leq 255$

Operation: $(W) .OR. k \rightarrow (W)$

Status Affected: Z

Encoding:

11	1000	kkkk	kkkk
----	------	------	------

Description: The contents of the W register is OR'ed with the eight bit literal 'k'. The result is placed in the W register.

Words: 1

Cycles: 1

Q Cycle Activity:

Q1	Q2	Q3	Q4
Decode	Read literal 'k'	Process data	Write to W

Example

```
IORLW    0x35
Before Instruction
          W = 0x9A
After Instruction
          W = 0xBF
          Z = 1
```

PIC16C84

IORWF **Inclusive OR W with f**

Syntax: [*label*] IORWF f,d

Operands: $0 \leq f \leq 127$
 $d \in [0,1]$

Operation: (W) .OR. (f) → (destination)

Status Affected: \bar{Z}

Encoding:

00	0100	dfff	ffff
----	------	------	------

Description: Inclusive OR the W register with register 'f'. If 'd' is 0 the result is placed in the W register. If 'd' is 1 the result is placed back in register 'f'.

Words: 1

Cycles: 1

Q Cycle Activity:

Q1	Q2	Q3	Q4
Decode	Read register 'f'	Process data	Write to destination

Example IORWF RESULT, 0

Before Instruction

RESULT = 0x13

W = 0x91

After Instruction

RESULT = 0x13

W = 0x93

Z = 1

MOVF **Move f**

Syntax: [*label*] MOVF f,d

Operands: $0 \leq f \leq 127$
 $d \in [0,1]$

Operation: (f) → (destination)

Status Affected: Z

Encoding:

00	1000	dfff	ffff
----	------	------	------

Description: The contents of register f is moved to a destination dependant upon the status of d. If d = 0, destination is W register. If d = 1, the destination is file register f itself. d = 1 is useful to test a file register since status flag Z is affected.

Words: 1

Cycles: 1

Q Cycle Activity:

Q1	Q2	Q3	Q4
Decode	Read register 'f'	Process data	Write to destination

Example MOVF FSR, 0

After Instruction

W = value in FSR register

Z = 1

MOVLW **Move Literal to W**

Syntax: [*label*] MOVLW k

Operands: $0 \leq k \leq 255$

Operation: $k \rightarrow (W)$

Status Affected: None

Encoding:

11	00xx	kkkk	kkkk
----	------	------	------

Description: The eight bit literal 'k' is loaded into W register. The don't cares will assemble as 0's.

Words: 1

Cycles: 1

Q Cycle Activity:

Q1	Q2	Q3	Q4
Decode	Read literal 'k'	Process data	Write to W

Example MOVLW 0x5A

After Instruction

W = 0x5A

MOVWF **Move W to f**

Syntax: [*label*] MOVWF f

Operands: $0 \leq f \leq 127$

Operation: (W) → (f)

Status Affected: None

Encoding:

00	0000	1fff	ffff
----	------	------	------

Description: Move data from W register to register 'f'.

Words: 1

Cycles: 1

Q Cycle Activity:

Q1	Q2	Q3	Q4
Decode	Read register 'f'	Process data	Write register 'f'

Example MOVWF OPTION_REG

Before Instruction

OPTION = 0xFF

W = 0x4F

After Instruction

OPTION = 0x4F

W = 0x4F

NOP	No Operation			
Syntax:	[<i>label</i>] NOP			
Operands:	None			
Operation:	No operation			
Status Affected:	None			
Encoding:	00	0000	0xx0	0000
Description:	No operation.			
Words:	1			
Cycles:	1			
Q Cycle Activity:	Q1	Q2	Q3	Q4
	Decode	No-Operation	No-Operation	No-Operation
Example	NOP			

RETFIE	Return from Interrupt			
Syntax:	[<i>label</i>] RETFIE			
Operands:	None			
Operation:	TOS → PC, 1 → GIE			
Status Affected:	None			
Encoding:	00	0000	0000	1001
Description:	Return from Interrupt. Stack is POPed and Top of Stack (TOS) is loaded in the PC. Interrupts are enabled by setting Global Interrupt Enable bit, GIE (INTCON<7>). This is a two cycle instruction.			
Words:	1			
Cycles:	2			
Q Cycle Activity:	Q1	Q2	Q3	Q4
1st Cycle	Decode	No-Operation	Set the GIE bit	Pop from the Stack
2nd Cycle	No-Operation	No-Operation	No-Operation	No-Operation
Example	RETFIE			

After Interrupt
 PC = TOS
 GIE = 1

OPTION	Load Option Register
Syntax:	[<i>label</i>] OPTION
Operands:	None
Operation:	(W) → OPTION
Status Affected:	None
Encoding:	00 0000 0110 0010
Description:	The contents of the W register are loaded in the OPTION register. This instruction is supported for code compatibility with PIC16C5X products. Since OPTION is a readable/writable register, the user can directly address it.
Words:	1
Cycles:	1
Example	To maintain upward compatibility with future PIC16CXX products, do not use this instruction.

PIC16C84

RETLW Return with Literal in W

Syntax: [*label*] RETLW k

Operands: $0 \leq k \leq 255$

Operation: $k \rightarrow (W)$;
 $TOS \rightarrow PC$

Status Affected: None

Encoding:

11	01xx	kkkk	kkkk
----	------	------	------

Description: The W register is loaded with the eight bit literal 'k'. The program counter is loaded from the top of the stack (the return address). This is a two cycle instruction.

Words: 1

Cycles: 2

Q Cycle Activity:	Q1	Q2	Q3	Q4
1st Cycle	Decode	Read literal 'k'	No-Operation	Write to W, Pop from the Stack
2nd Cycle	No-Operation	No-Operation	No-Operation	No-Operation

Example

```
CALL TABLE ;W contains table
           ;offset value
           ;W now has table value
•
•
•
TABLE ADDWF PC ;W = offset
      RETLW k1 ;Begin table
      RETLW k2 ;
      •
      •
      RETLW kn ; End of table
```

Before Instruction

W = 0x07

After Instruction

W = value of k8

RETURN Return from Subroutine

Syntax: [*label*] RETURN

Operands: None

Operation: $TOS \rightarrow PC$

Status Affected: None

Encoding:

00	0000	0000	1000
----	------	------	------

Description: Return from subroutine. The stack is POPed and the top of the stack (TOS) is loaded into the program counter. This is a two cycle instruction.

Words: 1

Cycles: 2

Q Cycle Activity:	Q1	Q2	Q3	Q4
1st Cycle	Decode	No-Operation	No-Operation	Pop from the Stack
2nd Cycle	No-Operation	No-Operation	No-Operation	No-Operation

Example

```
RETURN
After Interrupt
PC = TOS
```

RLF Rotate Left f through Carry

Syntax: [*label*] RLF f,d

Operands: $0 \leq f \leq 127$
 $d \in [0,1]$

Operation: See description below

Status Affected: C

Encoding:

00	1101	dfff	ffff
----	------	------	------

Description: The contents of register 'f' are rotated one bit to the left through the Carry Flag. If 'd' is 0 the result is placed in the W register. If 'd' is 1 the result is stored back in register 'f'.

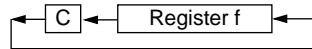

Words: 1

Cycles: 1

Q Cycle Activity:

	Q1	Q2	Q3	Q4
Decode				
Read register 'f'				
Process data				
Write to destination				

Example RLF REG1,0

Before Instruction
 REG1 = 1110 0110
 C = 0
 After Instruction
 REG1 = 1110 0110
 W = 1100 1100
 C = 1

RRF Rotate Right f through Carry

Syntax: [*label*] RRF f,d

Operands: $0 \leq f \leq 127$
 $d \in [0,1]$

Operation: See description below

Status Affected: C

Encoding:

00	1100	dfff	ffff
----	------	------	------

Description: The contents of register 'f' are rotated one bit to the right through the Carry Flag. If 'd' is 0 the result is placed in the W register. If 'd' is 1 the result is placed back in register 'f'.

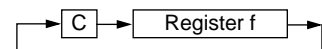

Words: 1

Cycles: 1

Q Cycle Activity:

	Q1	Q2	Q3	Q4
Decode				
Read register 'f'				
Process data				
Write to destination				

Example RRF REG1,0

Before Instruction
 REG1 = 1110 0110
 C = 0
 After Instruction
 REG1 = 1110 0110
 W = 0111 0011
 C = 0

PIC16C84

SLEEP

Syntax: [*label*] SLEEP

Operands: None

Operation: 00h → WDT,
0 → WDT prescaler,
1 → \overline{TO} ,
0 → \overline{PD}

Status Affected: \overline{TO} , \overline{PD}

Encoding:

00	0000	0110	0011
----	------	------	------

Description: The power-down status bit, \overline{PD} is cleared. Time-out status bit, \overline{TO} is set. Watchdog Timer and its prescaler are cleared.
The processor is put into SLEEP mode with the oscillator stopped. See Section 14.8 for more details.

Words: 1

Cycles: 1

Q Cycle Activity:

Q1	Q2	Q3	Q4
Decode	No-Operation	No-Operation	Go to Sleep

Example: SLEEP

SUBLW

Subtract W from Literal

Syntax: [*label*] SUBLW k

Operands: $0 \leq k \leq 255$

Operation: $k - (W) \rightarrow (W)$

Status Affected: C, DC, Z

Encoding:

11	110x	kkkk	kkkk
----	------	------	------

Description: The W register is subtracted (2's complement method) from the eight bit literal 'k'. The result is placed in the W register.

Words: 1

Cycles: 1

Q Cycle Activity:

Q1	Q2	Q3	Q4
Decode	Read literal 'k'	Process data	Write to W

Example 1: SUBLW 0x02

Before Instruction

W = 1
C = ?
Z = ?

After Instruction

W = 1
C = 1; result is positive
Z = 0

Example 2: Before Instruction

W = 2
C = ?
Z = ?

After Instruction

W = 0
C = 1; result is zero
Z = 1

Example 3: Before Instruction

W = 3
C = ?
Z = ?

After Instruction

W = 0xFF
C = 0; result is negative
Z = 0

SUBWF Subtract W from f

Syntax: [label] SUBWF f,d

Operands: $0 \leq f \leq 127$
 $d \in [0,1]$

Operation: $(f) - (W) \rightarrow (\text{destination})$

Status Affected: C, DC, Z

Encoding:

00	0010	dfff	ffff
----	------	------	------

Description: Subtract (2's complement method) W register from register 'f'. If 'd' is 0 the result is stored in the W register. If 'd' is 1 the result is stored back in register 'f'.

Words: 1

Cycles: 1

Q Cycle Activity:

Q1	Q2	Q3	Q4
Decode	Read register 'f'	Process data	Write to destination

Example 1: SUBWF REG1, 1

Before Instruction

REG1 = 3
W = 2
C = ?
Z = ?

After Instruction

REG1 = 1
W = 2
C = 1; result is positive
Z = 0

Example 2: Before Instruction

REG1 = 2
W = 2
C = ?
Z = ?

After Instruction

REG1 = 0
W = 2
C = 1; result is zero
Z = 1

Example 3: Before Instruction

REG1 = 1
W = 2
C = ?
Z = ?

After Instruction

REG1 = 0xFF
W = 2
C = 0; result is negative
Z = 0

SWAPF Swap Nibbles in f

Syntax: [label] SWAPF f,d

Operands: $0 \leq f \leq 127$
 $d \in [0,1]$

Operation: $(f<3:0>) \rightarrow (\text{destination}<7:4>)$,
 $(f<7:4>) \rightarrow (\text{destination}<3:0>)$

Status Affected: None

Encoding:

00	1110	dfff	ffff
----	------	------	------

Description: The upper and lower nibbles of register 'f' are exchanged. If 'd' is 0 the result is placed in W register. If 'd' is 1 the result is placed in register 'f'.

Words: 1

Cycles: 1

Q Cycle Activity:

Q1	Q2	Q3	Q4
Decode	Read register 'f'	Process data	Write to destination

Example SWAPF REG, 0

Before Instruction

REG1 = 0xA5

After Instruction

REG1 = 0xA5
W = 0x5A

TRIS Load TRIS Register

Syntax: [label] TRIS f

Operands: $5 \leq f \leq 7$

Operation: $(W) \rightarrow \text{TRIS register } f$;

Status Affected: None

Encoding:

00	0000	0110	0fff
----	------	------	------

Description: The instruction is supported for code compatibility with the PIC16C5X products. Since TRIS registers are readable and writable, the user can directly address them.

Words: 1

Cycles: 1

Example

To maintain upward compatibility with future PIC16CXX products, do not use this instruction.

PIC16C84

XORLW Exclusive OR Literal with W

Syntax: `[label] XORLW k`
 Operands: $0 \leq k \leq 255$
 Operation: $(W) .XOR. k \rightarrow (W)$
 Status Affected: Z
 Encoding:

11	1010	kkkk	kkkk
----	------	------	------

Description: The contents of the W register are XOR'ed with the eight bit literal 'k'. The result is placed in the W register.

Words: 1
 Cycles: 1
 Q Cycle Activity:

Q1	Q2	Q3	Q4
Decode	Read literal 'k'	Process data	Write to W

Example: `XORLW 0xAF`
 Before Instruction
 W = 0xB5
 After Instruction
 W = 0x1A

XORWF Exclusive OR W with f

Syntax: `[label] XORWF f,d`
 Operands: $0 \leq f \leq 127$
 $d \in [0,1]$
 Operation: $(W) .XOR. (f) \rightarrow (\text{destination})$
 Status Affected: Z
 Encoding:

00	0110	dfff	ffff
----	------	------	------

Description: Exclusive OR the contents of the W register with register 'f'. If 'd' is 0 the result is stored in the W register. If 'd' is 1 the result is stored back in register 'f'.

Words: 1
 Cycles: 1
 Q Cycle Activity:

Q1	Q2	Q3	Q4
Decode	Read register 'f'	Process data	Write to destination

Example `XORWF REG 1`
 Before Instruction
 REG = 0xAF
 W = 0xB5
 After Instruction
 REG = 0x1A
 W = 0xB5

10.0 DEVELOPMENT SUPPORT

10.1 Development Tools

The PICmicro™ microcontrollers are supported with a full range of hardware and software development tools:

- PICMASTER®/PICMASTER CE Real-Time In-Circuit Emulator
- ICEPIC Low-Cost PIC16C5X and PIC16CXXX In-Circuit Emulator
- PRO MATE® II Universal Programmer
- PICSTART® Plus Entry-Level Prototype Programmer
- PICDEM-1 Low-Cost Demonstration Board
- PICDEM-2 Low-Cost Demonstration Board
- PICDEM-3 Low-Cost Demonstration Board
- MPASM Assembler
- MPLAB™ SIM Software Simulator
- MPLAB-C (C Compiler)
- Fuzzy Logic Development System (*fuzzyTECH*®-MP)

10.2 PICMASTER: High Performance Universal In-Circuit Emulator with MPLAB IDE

The PICMASTER Universal In-Circuit Emulator is intended to provide the product development engineer with a complete microcontroller design tool set for all microcontrollers in the SX, PIC14C000, PIC16C5X, PIC16CXXX and PIC17CXX families. PICMASTER is supplied with the MPLAB™ Integrated Development Environment (IDE), which allows editing, “make” and download, and source debugging from a single environment.

Interchangeable target probes allow the system to be easily reconfigured for emulation of different processors. The universal architecture of the PICMASTER allows expansion to support all new Microchip microcontrollers.

The PICMASTER Emulator System has been designed as a real-time emulation system with advanced features that are generally found on more expensive development tools. The PC compatible 386 (and higher) machine platform and Microsoft Windows® 3.x environment were chosen to best make these features available to you, the end user.

A CE compliant version of PICMASTER is available for European Union (EU) countries.

10.3 ICEPIC: Low-Cost PICmicro™ In-Circuit Emulator

ICEPIC is a low-cost in-circuit emulator solution for the Microchip PIC12CXXX, PIC16C5X and PIC16CXXX families of 8-bit OTP microcontrollers.

ICEPIC is designed to operate on PC-compatible machines ranging from 286-AT® through Pentium™ based machines under Windows 3.x environment. ICEPIC features real time, non-intrusive emulation.

10.4 PRO MATE II: Universal Programmer

The PRO MATE II Universal Programmer is a full-featured programmer capable of operating in stand-alone mode as well as PC-hosted mode.

The PRO MATE II has programmable VDD and VPP supplies which allows it to verify programmed memory at VDD min and VDD max for maximum reliability. It has an LCD display for displaying error messages, keys to enter commands and a modular detachable socket assembly to support various package types. In stand-alone mode the PRO MATE II can read, verify or program PIC12CXXX, PIC14C000, PIC16C5X, PIC16CXXX and PIC17CXX devices. It can also set configuration and code-protect bits in this mode.

10.5 PICSTART Plus Entry Level Development System

The PICSTART programmer is an easy-to-use, low-cost prototype programmer. It connects to the PC via one of the COM (RS-232) ports. MPLAB Integrated Development Environment software makes using the programmer simple and efficient. PICSTART Plus is not recommended for production programming.

PICSTART Plus supports all PIC12CXXX, PIC14C000, PIC16C5X, PIC16CXXX and PIC17CXX devices with up to 40 pins. Larger pin count devices such as the PIC16C923 and PIC16C924 may be supported with an adapter socket.

PIC16C84

10.6 PICDEM-1 Low-Cost PICmicro Demonstration Board

The PICDEM-1 is a simple board which demonstrates the capabilities of several of Microchip's microcontrollers. The microcontrollers supported are: PIC16C5X (PIC16C54 to PIC16C58A), PIC16C61, PIC16C62X, PIC16C71, PIC16C8X, PIC17C42, PIC17C43 and PIC17C44. All necessary hardware and software is included to run basic demo programs. The users can program the sample microcontrollers provided with the PICDEM-1 board, on a PRO MATE II or PICSTART-Plus programmer, and easily test firmware. The user can also connect the PICDEM-1 board to the PICMASTER emulator and download the firmware to the emulator for testing. Additional prototype area is available for the user to build some additional hardware and connect it to the microcontroller socket(s). Some of the features include an RS-232 interface, a potentiometer for simulated analog input, push-button switches and eight LEDs connected to PORTB.

10.7 PICDEM-2 Low-Cost PIC16CXX Demonstration Board

The PICDEM-2 is a simple demonstration board that supports the PIC16C62, PIC16C64, PIC16C65, PIC16C73 and PIC16C74 microcontrollers. All the necessary hardware and software is included to run the basic demonstration programs. The user can program the sample microcontrollers provided with the PICDEM-2 board, on a PRO MATE II programmer or PICSTART-Plus, and easily test firmware. The PICMASTER emulator may also be used with the PICDEM-2 board to test firmware. Additional prototype area has been provided to the user for adding additional hardware and connecting it to the microcontroller socket(s). Some of the features include a RS-232 interface, push-button switches, a potentiometer for simulated analog input, a Serial EEPROM to demonstrate usage of the I²C bus and separate headers for connection to an LCD module and a keypad.

10.8 PICDEM-3 Low-Cost PIC16CXXX Demonstration Board

The PICDEM-3 is a simple demonstration board that supports the PIC16C923 and PIC16C924 in the PLCC package. It will also support future 44-pin PLCC microcontrollers with a LCD Module. All the necessary hardware and software is included to run the basic demonstration programs. The user can program the sample microcontrollers provided with the PICDEM-3 board, on a PRO MATE II programmer or PICSTART Plus with an adapter socket, and easily test firmware. The PICMASTER emulator may also be used with the PICDEM-3 board to test firmware. Additional prototype area has been provided to the user for adding hardware and connecting it to the microcontroller socket(s). Some of the features include

an RS-232 interface, push-button switches, a potentiometer for simulated analog input, a thermistor and separate headers for connection to an external LCD module and a keypad. Also provided on the PICDEM-3 board is an LCD panel, with 4 commons and 12 segments, that is capable of displaying time, temperature and day of the week. The PICDEM-3 provides an additional RS-232 interface and Windows 3.1 software for showing the demultiplexed LCD signals on a PC. A simple serial interface allows the user to construct a hardware demultiplexer for the LCD signals.

10.9 MPLAB™ Integrated Development Environment Software

The MPLAB IDE Software brings an ease of software development previously unseen in the 8-bit microcontroller market. MPLAB is a windows based application which contains:

- A full featured editor
- Three operating modes
 - editor
 - emulator
 - simulator
- A project manager
- Customizable tool bar and key mapping
- A status bar with project information
- Extensive on-line help

MPLAB allows you to:

- Edit your source files (either assembly or 'C')
- One touch assemble (or compile) and download to PICmicro tools (automatically updates all project information)
- Debug using:
 - source files
 - absolute listing file
- Transfer data dynamically via DDE (soon to be replaced by OLE)
- Run up to four emulators on the same PC

The ability to use MPLAB with Microchip's simulator allows a consistent platform and the ability to easily switch from the low cost simulator to the full featured emulator with minimal retraining due to development tools.

10.10 Assembler (MPASM)

The MPASM Universal Macro Assembler is a PC-hosted symbolic assembler. It supports all microcontroller series including the PIC12C5XX, PIC14000, PIC16C5X, PIC16CXXX, and PIC17CXX families.

MPASM offers full featured Macro capabilities, conditional assembly, and several source and listing formats. It generates various object code formats to support Microchip's development tools as well as third party programmers.

MPASM allows full symbolic debugging from PICMASTER, Microchip's Universal Emulator System.

MPASM has the following features to assist in developing software for specific use applications.

- Provides translation of Assembler source code to object code for all Microchip microcontrollers.
- Macro assembly capability.
- Produces all the files (Object, Listing, Symbol, and special) required for symbolic debug with Microchip's emulator systems.
- Supports Hex (default), Decimal and Octal source and listing formats.

MPASM provides a rich directive language to support programming of the PICmicro. Directives are helpful in making the development of your assemble source code shorter and more maintainable.

10.11 Software Simulator (MPLAB-SIM)

The MPLAB-SIM Software Simulator allows code development in a PC host environment. It allows the user to simulate the PICmicro series microcontrollers on an instruction level. On any given instruction, the user may examine or modify any of the data areas or provide external stimulus to any of the pins. The input/output radix can be set by the user and the execution can be performed in; single step, execute until break, or in a trace mode.

MPLAB-SIM fully supports symbolic debugging using MPLAB-C and MPASM. The Software Simulator offers the low cost flexibility to develop and debug code outside of the laboratory environment making it an excellent multi-project software development tool.

10.12 C Compiler (MPLAB-C)

The MPLAB-C Code Development System is a complete 'C' compiler and integrated development environment for Microchip's PICmicro™ family of microcontrollers. The compiler provides powerful integration capabilities and ease of use not found with other compilers.

For easier source level debugging, the compiler provides symbol information that is compatible with the MPLAB IDE memory display.

10.13 Fuzzy Logic Development System (fuzzyTECH-MP)

fuzzyTECH-MP fuzzy logic development tool is available in two versions - a low cost introductory version, MP Explorer, for designers to gain a comprehensive working knowledge of fuzzy logic system design; and a full-featured version, *fuzzyTECH-MP*, edition for implementing more complex systems.

Both versions include Microchip's *fuzzyLAB™* demonstration board for hands-on experience with fuzzy logic systems implementation.

10.14 MP-DriveWay™ – Application Code Generator

MP-DriveWay is an easy-to-use Windows-based Application Code Generator. With MP-DriveWay you can visually configure all the peripherals in a PICmicro device and, with a click of the mouse, generate all the initialization and many functional code modules in C language. The output is fully compatible with Microchip's MPLAB-C C compiler. The code produced is highly modular and allows easy integration of your own code. MP-DriveWay is intelligent enough to maintain your code through subsequent code generation.

10.15 SEEVAL® Evaluation and Programming System

The SEEVAL SEEPROM Designer's Kit supports all Microchip 2-wire and 3-wire Serial EEPROMs. The kit includes everything necessary to read, write, erase or program special features of any Microchip SEEPROM product including Smart Serials™ and secure serials. The Total Endurance™ Disk is included to aid in trade-off analysis and reliability calculations. The total kit can significantly reduce time-to-market and result in an optimized system.

10.16 KEELOQ® Evaluation and Programming Tools

KEELOQ evaluation and programming tools support Microchips HCS Secure Data Products. The HCS evaluation kit includes an LCD display to show changing codes, a decoder to decode transmissions, and a programming interface to program test transmitters.

PIC16C84

TABLE 10-1: DEVELOPMENT TOOLS FROM MICROCHIP

	PIC12C5XX	PIC14000	PIC16C5X	PIC16CXXX	PIC16C6X	PIC16C7XX	PIC16C8X	PIC16C9XX	PIC17C4X	PIC17C75X	24CXX 25CXX 93CXX	HCS200 HCS300 HCS301
Emulator Products												
PICMASTER [®] / PICMASTER-CE In-Circuit Emulator	✓	✓	✓	✓	✓	✓	✓	✓	✓	Available 3097		
ICEPIC Low-Cost In-Circuit Emulator	✓		✓	✓	✓	✓	✓					
Software Tools												
MPLAB [™] Integrated Development Environment			✓	✓	✓	✓	✓	✓	✓	✓		
MPLAB [™] C Compiler	✓	✓	✓	✓	✓	✓	✓	✓	✓	✓		
fuzzyTECH [®] -MP Explorer/Edition Fuzzy Logic Dev. Tool	✓	✓	✓	✓	✓	✓	✓	✓	✓			
MP-DriveWay [™] Applications Code Generator			✓	✓	✓	✓	✓		✓			
Total Endurance [™] Software Model											✓	
Programmers												
PICSTART [®] Lite Ultra Low-Cost Dev. Kit			✓		✓	✓	✓					
PICSTART [®] Plus Low-Cost Universal Dev. Kit	✓	✓	✓	✓	✓	✓	✓	✓	✓	✓	✓	✓
PRO MATE [®] II Universal Programmer	✓	✓	✓	✓	✓	✓	✓		✓	✓	✓	✓
KEELOQ [®] Programmer												
SEEVAL [®] Designers Kit											✓	
Demo Boards												
PICDEM-1		✓		✓			✓		✓			
PICDEM-2					✓							
PICDEM-3								✓				
KEELOQ [®] Evaluation Kit												✓

11.0 ELECTRICAL CHARACTERISTICS FOR PIC16C84

Absolute Maximum Ratings †

Ambient temperature under bias.....	-55°C to +125°C
Storage temperature	-65°C to +150°C
Voltage on VDD with respect to VSS	-0.3 to +7.5V
Voltage on $\overline{\text{MCLR}}$ with respect to VSS ⁽²⁾	-0.3 to +14V
Voltage on all other pins with respect to VSS	-0.6V to (VDD + 0.6V)
Total power dissipation ⁽¹⁾	800 mW
Maximum current out of VSS pin	150 mA
Maximum current into VDD pin	100 mA
Input clamp current, I _{IK} (V _I < 0 or V _I > V _{DD}).....	± 20 mA
Output clamp current, I _{OK} (V _O < 0 or V _O > V _{DD})	± 20 mA
Maximum output current sunk by any I/O pin.....	25 mA
Maximum output current sourced by any I/O pin	20 mA
Maximum current sunk by PORTA	80 mA
Maximum current sourced by PORTA	50 mA
Maximum current sunk by PORTB.....	150 mA
Maximum current sourced by PORTB.....	100 mA

Note 1: Power dissipation is calculated as follows: $P_{dis} = V_{DD} \times \{I_{DD} - \sum I_{OH}\} + \sum \{(V_{DD} - V_{OH}) \times I_{OH}\} + \sum (V_{OL} \times I_{OL})$

Note 2: Voltage spikes below V_{SS} at the $\overline{\text{MCLR}}$ pin, inducing currents greater than 80 mA, may cause latch-up. Thus, a series resistor of 50-100Ω should be used when applying a “low” level to the $\overline{\text{MCLR}}$ pin rather than pulling this pin directly to V_{SS}.

† NOTICE: Stresses above those listed under “Absolute Maximum Ratings” may cause permanent damage to the device. This is a stress rating only and functional operation of the device at those or any other conditions above those indicated in the operation listings of this specification is not implied. Exposure to maximum rating conditions for extended periods may affect device reliability.

PIC16C84

TABLE 11-1 CROSS REFERENCE OF DEVICE SPECS FOR OSCILLATOR CONFIGURATIONS AND FREQUENCIES OF OPERATION (COMMERCIAL DEVICES)

OSC	PIC16C84-04	PIC16C84-10	PIC16LC84-04
RC	VDD: 4.0V to 6.0V IDD: 4.5 mA max. at 5.5V IPD: 100 μ A max. at 4.0V WDT dis Freq: 4.0 MHz max.	VDD: 4.5V to 5.5V IDD: 1.8 mA typ. at 5.5V IPD: 40.0 μ A typ. at 4.5V WDT dis Freq: 4.0 MHz max.	VDD: 2.0V to 6.0V IDD: 4.5 mA max. at 5.5V IPD: 100 μ A max. at 4V WDT dis Freq: 2.0 MHz max.
XT	VDD: 4.0V to 6.0V IDD: 4.5 mA max. at 5.5V IPD: 100 μ A max. at 4.0V WDT dis Freq: 4.0 MHz max.	VDD: 4.5V to 5.5V IDD: 1.8 mA typ. at 5.5V IPD: 40.0 μ A typ. at 4.5V WDT dis Freq: 4.0 MHz max.	VDD: 2.0V to 6.0V IDD: 4.5 mA max. at 5.5V IPD: 100 μ A max. at 4V WDT dis Freq: 2.0 MHz max.
HS	VDD: 4.5V to 5.5V IDD: 4.5 mA typ. at 5.5V IPD: 40.0 μ A typ. at 4.5V WDT dis Freq: 4.0 MHz max.	VDD: 4.5V to 5.5V IDD: 10 mA max. at 5.5V typ. IPD: 40.0 μ A typ. at 4.5V WDT dis Freq: 10 MHz max.	Do not use in HS mode
LP	VDD: 4.0V to 6.0V IDD: 60 μ A typ. at 32 kHz, 2.0V IPD: 26 μ A typ. at 2.0V WDT dis Freq: 200 kHz max.	Do not use in LP mode	VDD: 2.0V to 6.0V IDD: 400 μ A max. at 32 kHz, 2.0V IPD: 100 μ A max. at 4.0V WDT dis Freq: 200 kHz max.

The shaded sections indicate oscillator selections which are tested for functionality, but not for MIN/MAX specifications. It is recommended that the user select the device type that ensures the specifications required.

11.1 DC CHARACTERISTICS: PIC16C84-04 (Commercial, Industrial) PIC16C84-10 (Commercial, Industrial)

DC Characteristics Power Supply Pins		Standard Operating Conditions (unless otherwise stated) Operating temperature 0°C ≤ TA ≤ +70°C (commercial) -40°C ≤ TA ≤ +85°C (industrial)					
Parameter No.	Sym	Characteristic	Min	Typ†	Max	Units	Conditions
D001 D001A	VDD	Supply Voltage	4.0 4.5	—	6.0 5.5	V V	XT, RC and LP osc configuration HS osc configuration
D002	VDR	RAM Data Retention Voltage ⁽¹⁾	1.5*	—	—	V	Device in SLEEP mode
D003	VPOR	VDD start voltage to ensure internal Power-on Reset signal	—	VSS	—	V	See section on Power-on Reset for details
D004	SVDD	VDD rise rate to ensure internal Power-on Reset signal	0.05*	—	—	V/ms	See section on Power-on Reset for details
D010 D010A D013	IDD	Supply Current ⁽²⁾	— — —	1.8 7.3 5.0	4.5 10 10	mA mA mA	RC and XT osc configuration ⁽⁴⁾ FOSC = 4 MHz, VDD = 5.5V FOSC = 4 MHz, VDD = 5.5V (During EEPROM programming) HS osc configuration (PIC16C84-10) FOSC = 10 MHz, VDD = 5.5V
D020 D021 D021A	IPD	Power-down Current ⁽³⁾	— — —	40 38 38	100 100 100	μA μA μA	VDD = 4.0V, WDT enabled, industrial VDD = 4.0V, WDT disabled, commercial VDD = 4.0V, WDT disabled, industrial

* These parameters are characterized but not tested.

† Data in "Typ" column is at 5.0V, 25°C unless otherwise stated. These parameters are for design guidance only and are not tested.

Note 1: This is the limit to which VDD can be lowered in SLEEP mode without losing RAM data.

2: The supply current is mainly a function of the operating voltage and frequency. Other factors such as I/O pin loading and switching rate, oscillator type, internal code execution pattern, and temperature also have an impact on current consumption.

The test conditions for all IDD measurements in active operation mode are:

OSC1 = external square wave, from rail to rail; all I/O pins tristated, pulled to VDD, T0CKI = VDD, MCLR = VDD; WDT enabled/disabled as specified.

3: The power down current in SLEEP mode does not depend on the oscillator type. Power-down current is measured with the part in SLEEP mode, with all I/O pins in hi-impedance state and tied to VDD or VSS.

4: For RC osc configuration, current through Rext is not included. The current through the resistor can be estimated by the formula $I_R = V_{DD}/2R_{ext}$ (mA) with Rext in kOhm.

PIC16C84

11.2 DC CHARACTERISTICS PIC16LC84-04 (Commercial, Industrial)

DC Characteristics Power Supply Pins		Standard Operating Conditions (unless otherwise stated) Operating temperature 0°C ≤ TA ≤ +70°C (commercial) -40°C ≤ TA ≤ +85°C (industrial)					
Parameter No.	Sym	Characteristic	Min	Typ†	Max	Units	Conditions
D001	VDD	Supply Voltage	2.0	—	6.0	V	XT, RC, and LP osc configuration
D002	VDR	RAM Data Retention Voltage ⁽¹⁾	1.5 *	—	—	V	Device in SLEEP mode
D003	VPOR	VDD start voltage to ensure internal Power-on Reset signal	—	VSS	—	V	See section on Power-on Reset for details
D004	SVDD	VDD rise rate to ensure internal Power-on Reset signal	0.05*	—	—	V/ms	See section on Power-on Reset for details
D010 D010A D014	IDD	Supply Current ⁽²⁾	— — —	1 7.3 60	4 10 400	mA mA μA	RC and XT osc configuration ⁽⁴⁾ FOSC = 2 MHz, VDD = 5.5V FOSC = 2 MHz, VDD = 5.5V (During EEPROM programming) LP osc configuration FOSC = 32 kHz, VDD = 2.0V, WDT disabled
D020 D021 D021A	IPD	Power-down Current ⁽³⁾	— — —	26 26 26	100 100 100	μA μA μA	VDD = 2.0V, WDT enabled, industrial VDD = 2.0V, WDT disabled, commercial VDD = 2.0V, WDT disabled, industrial

* These parameters are characterized but not tested.

† Data in "Typ" column is at 5.0V, 25°C unless otherwise stated. These parameters are for design guidance only and are not tested.

Note 1: This is the limit to which VDD can be lowered in SLEEP mode without losing RAM data.

2: The supply current is mainly a function of the operating voltage and frequency. Other factors such as I/O pin loading and switching rate, oscillator type, internal code execution pattern, and temperature also have an impact on the current consumption.

The test conditions for all IDD measurements in active operation mode are:

OSC1=external square wave, from rail to rail; all I/O pins tristated, pulled to VDD, T0CKI = VDD,

MCLR = VDD; WDT enabled/disabled as specified.

3: The power down current in SLEEP mode does not depend on the oscillator type. Power-down current is measured with the part in SLEEP mode, with all I/O pins in hi-impedance state and tied to VDD or VSS.

4: For RC osc configuration, current through Rext is not included. The current through the resistor can be estimated by the formula $I_R = V_{DD}/2R_{ext}$ (mA) with Rext in kOhm.

11.3 DC CHARACTERISTICS: PIC16C84-04 (Commercial, Industrial) PIC16C84-10 (Commercial, Industrial) PIC16LC84-04 (Commercial, Industrial)

DC Characteristics All Pins Except Power Supply Pins		Standard Operating Conditions (unless otherwise stated) Operating temperature $0^{\circ}\text{C} \leq T_A \leq +70^{\circ}\text{C}$ (commercial) $-40^{\circ}\text{C} \leq T_A \leq +85^{\circ}\text{C}$ (industrial) Operating voltage V_{DD} range as described in DC spec Section 11-1 and Section 11.2.					
Parameter No.	Sym	Characteristic	Min	Typ†	Max	Units	Conditions
D030 D030A D031 D032 D033	V_{IL}	Input Low Voltage I/O ports with TTL buffer with Schmitt Trigger buffer MCLR, RA4/T0CKI, OSC1 (RC mode) OSC1 (XT, HS and LP modes) ⁽¹⁾	V_{SS} V_{SS} V_{SS} V_{SS} V_{SS}	— — — — —	0.8 0.16 V_{DD} 0.2 V_{DD} 0.2 V_{DD} 0.3 V_{DD}	V V V V V	$4.5 \leq V_{DD} \leq 5.5\text{V}$ entire range ⁽⁴⁾ entire range
D040 D040A D041 D042 D043	V_{IH}	Input High Voltage I/O ports with TTL buffer with Schmitt Trigger buffer MCLR, RA4/T0CKI, OSC1 (RC mode) OSC1 (XT, HS and LP modes) ⁽¹⁾	0.36 V_{DD} 0.48 V_{DD} 0.45 V_{DD} 0.85 V_{DD} 0.7 V_{DD}	— — — — —	V_{DD} V_{DD} V_{DD} V_{DD} V_{DD}	V V V V V	$4.5 \leq V_{DD} \leq 5.5\text{V}$ entire range ⁽⁴⁾ entire range
D070	IPURB	PORTB weak pull-up current	50*	250*	400*	μA	$V_{DD} = 5\text{V}$, $V_{PIN} = V_{SS}$
D060 D061 D063	I_{IL}	Input Leakage Current ^(2,3) I/O ports MCLR, RA4/T0CKI OSC1/CLKIN	— — —	— — —	± 1 ± 5 ± 5	μA μA μA	$V_{SS} \leq V_{PIN} \leq V_{DD}$, Pin at hi-impedance $V_{SS} \leq V_{PIN} \leq V_{DD}$ $V_{SS} \leq V_{PIN} \leq V_{DD}$, XT, HS and LP osc configuration
D080 D083	V_{OL}	Output Low Voltage I/O ports OSC2/CLKOUT (RC osc configuration)	— —	— —	0.6 0.6	V V	$I_{OL} = 8.5\text{ mA}$, $V_{DD} = 4.5\text{V}$ $I_{OL} = 1.6\text{ mA}$, $V_{DD} = 4.5\text{V}$
D090 D093	V_{OH}	Output High Voltage I/O ports ⁽³⁾ OSC2/CLKOUT (RC osc configuration)	$V_{DD} - 0.7$ $V_{DD} - 0.7$	— —	— —	V V	$I_{OH} = -3.0\text{ mA}$, $V_{DD} = 4.5\text{V}$ $I_{OH} = -1.3\text{ mA}$, $V_{DD} = 4.5\text{V}$

* These parameters are characterized but not tested.

† Data in "Typ" column is at 5.0V, 25°C unless otherwise stated. These parameters are for design guidance only and are not tested.

Note 1: In RC oscillator configuration, the OSC1/CLKIN pin is a Schmitt Trigger input. It is not recommended that the PIC16C84 be driven with external clock in RC mode.

2: The leakage current on the MCLR pin is strongly dependent on the applied voltage level. The specified levels represent normal operating conditions. Higher leakage current may be measured at different input voltages.

3: Negative current is defined as coming out of the pin.

4: The user may use better of the two specs.

PIC16C84

11.4 DC CHARACTERISTICS: PIC16C84-04 (Commercial, Industrial) PIC16C84-10 (Commercial, Industrial) PIC16LC84-04 (Commercial, Industrial)

DC Characteristics All Pins Except Power Supply Pins		Standard Operating Conditions (unless otherwise stated) Operating temperature $0^{\circ}\text{C} \leq T_A \leq +70^{\circ}\text{C}$ (commercial) $-40^{\circ}\text{C} \leq T_A \leq +85^{\circ}\text{C}$ (industrial) Operating voltage V_{DD} range as described in DC spec Section 11-1 and Section 11.2.					
Parameter No.	Sym	Characteristic	Min	Typ†	Max	Units	Conditions
Capacitive Loading Specs on Output Pins							
D100	Cosc2	OSC2/CLKOUT pin	—	—	15	pF	In XT, HS and LP modes when external clock is used to drive OSC1.
D101	Cio	All I/O pins and OSC2 (RC mode)	—	—	50	pF	
Data EEPROM Memory							
D120	Ed	Endurance	1M	10M	—	E/W	25°C at 5V V_{MIN} = Minimum operating voltage
D121	VDRW	V_{DD} for read/write	V_{MIN}	—	6.0	V	
D122	TDEW	Erase/Write cycle time ⁽¹⁾	—	10	20*	ms	
Program EEPROM Memory							
D130	EP	Endurance	100	1000	—	E/W	V_{MIN} = Minimum operating voltage
D131	VPR	V_{DD} for read	V_{MIN}	—	6.0	V	
D132	VPEW	V_{DD} for erase/write	4.5	—	5.5	V	
D133	TPEW	Erase/Write cycle time ⁽¹⁾	—	10	—	ms	

* These parameters are characterized but not tested.

† Data in "Typ" column is at 5.0V, 25°C unless otherwise stated. These parameters are for design guidance only and are not tested.

Note 1: The user should use interrupts or poll the EEIF or WR bits to ensure the write cycle has completed.

TABLE 11-2 TIMING PARAMETER SYMBOLOGY

The timing parameter symbols have been created following one of the following formats:

1. TppS2ppS
2. TppS

T			
F	Frequency	T	Time

Lowercase symbols (pp) and their meanings:

pp			
2	to	os,osc	OSC1
ck	CLKOUT	ost	oscillator start-up timer
cy	cycle time	pwrt	power-up timer
io	I/O port	rbt	RBx pins
inp	INT pin	t0	T0CKI
mc	MCLR	wdt	watchdog timer

Uppercase symbols and their meanings:

S			
F	Fall	P	Period
H	High	R	Rise
I	Invalid (Hi-impedance)	V	Valid
L	Low	Z	Hi-impedance

FIGURE 11-1: PARAMETER MEASUREMENT INFORMATION

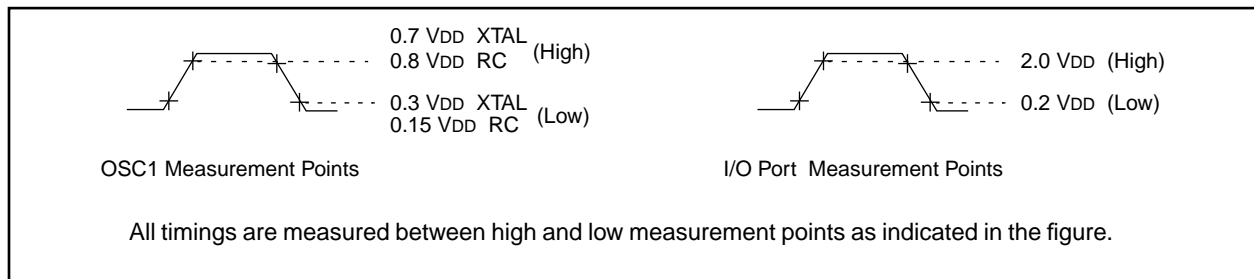
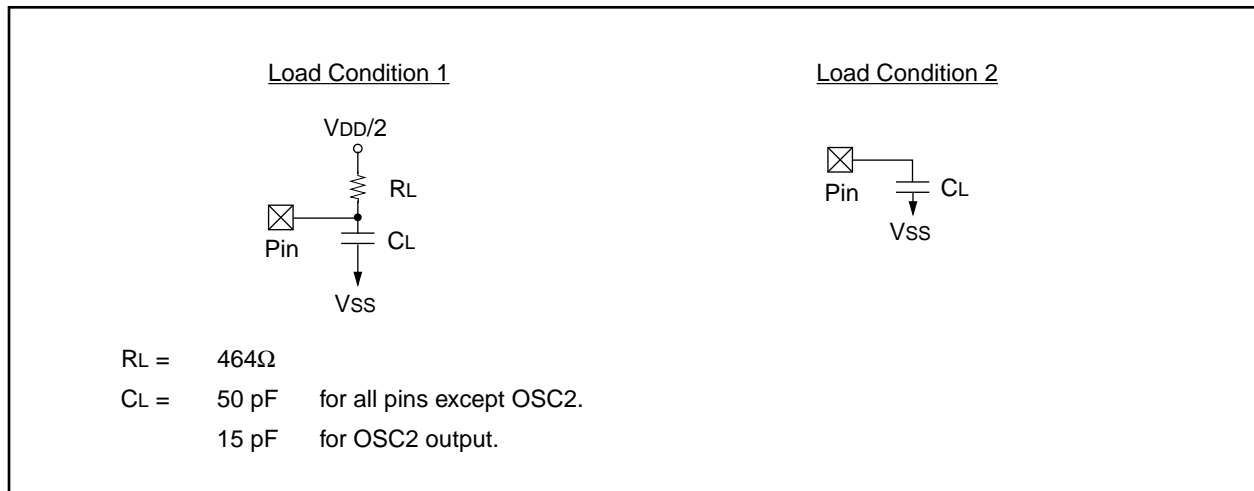

FIGURE 11-2: LOAD CONDITIONS



PIC16C84

11.5 Timing Diagrams and Specifications

FIGURE 11-3: EXTERNAL CLOCK TIMING

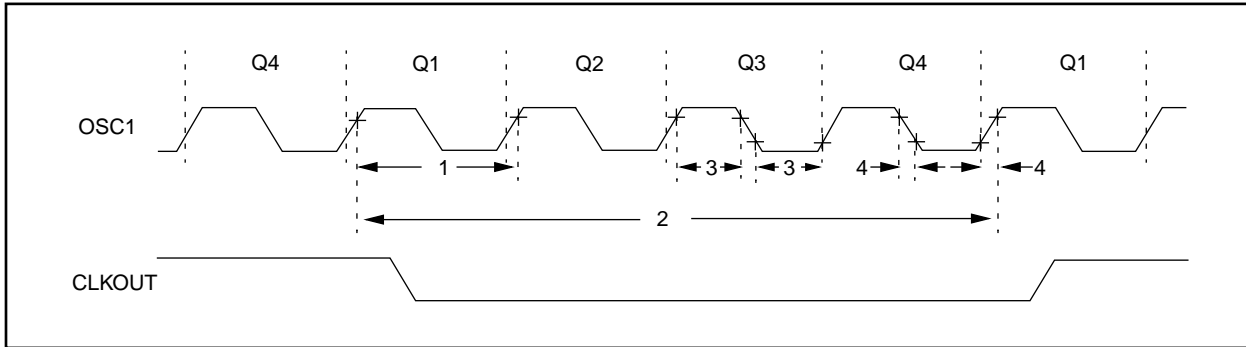

TABLE 11-3 EXTERNAL CLOCK TIMING REQUIREMENTS

Parameter No.	Sym	Characteristic	Min	Typ†	Max	Units	Conditions
	Fosc	External CLKIN Frequency⁽¹⁾	DC	—	2	MHz	XT, RC osc PIC16LC84-04
			DC	—	4	MHz	XT, RC osc PIC16C84-04
			DC	—	10	MHz	HS osc PIC16C84-10
			DC	—	200	kHz	LP osc PIC16LC84-04
		Oscillator Frequency⁽¹⁾	DC	—	2	MHz	RC osc PIC16LC84-04
			DC	—	4	MHz	RC osc PIC16C84-04
			0.1	—	2	MHz	XT osc PIC16LC84-04
			0.1	—	4	MHz	XT osc PIC16C84-04
			1	—	10	MHz	HS osc PIC16C84-10
			DC	—	200	kHz	LP osc PIC16LC84-04
1	Tosc	External CLKIN Period⁽¹⁾	500	—	—	ns	XT, RC osc PIC16LC84-04
			250	—	—	ns	XT, RC osc PIC16C84-04
			100	—	—	ns	HS osc PIC16C84-10
			5	—	—	μs	LP osc PIC16LC84-04
		Oscillator Period⁽¹⁾	500	—	—	ns	RC osc PIC16LC84-04
			250	—	—	ns	RC osc PIC16C84-04
			500	—	10,000	ns	XT osc PIC16LC84-04
			250	—	10,000	ns	XT osc PIC16C84-04
100	—	1,000	ns	HS osc PIC16C84-10			
	5	—	—	μs	LP osc PIC16LC84-04		
2	TCY	Instruction Cycle Time⁽¹⁾	0.4	4/Fosc	DC	μs	
3	TosL, TosH	Clock in (OSC1) High or Low Time	60 *	—	—	ns	XT osc PIC16LC84-04
			50 *	—	—	ns	XT osc PIC16C84-04
			2 *	—	—	μs	LP osc PIC16LC84-04
			35 *	—	—	ns	HS osc PIC16C84-10
4	TosR, TosF	Clock in (OSC1) Rise or Fall Time	25 *	—	—	ns	XT osc PIC16C84-04
			50 *	—	—	ns	LP osc PIC16LC84-04
			15 *	—	—	ns	HS osc PIC16C84-10

* These parameters are characterized but not tested.

† Data in "Typ" column is at 5.0V, 25°C unless otherwise stated. These parameters are for design guidance only and are not tested.

Note 1: Instruction cycle period (TCY) equals four times the input oscillator time base period. All specified values are based on characterization data for that particular oscillator type under standard operating conditions with the device executing code. Exceeding these specified limits may result in an unstable oscillator operation and/or higher than expected current consumption. All devices are tested to operate at "min." values with an external clock applied to the OSC1 pin. When an external clock input is used, the "Max." cycle time limit is "DC" (no clock) for all devices.

FIGURE 11-4: CLKOUT AND I/O TIMING

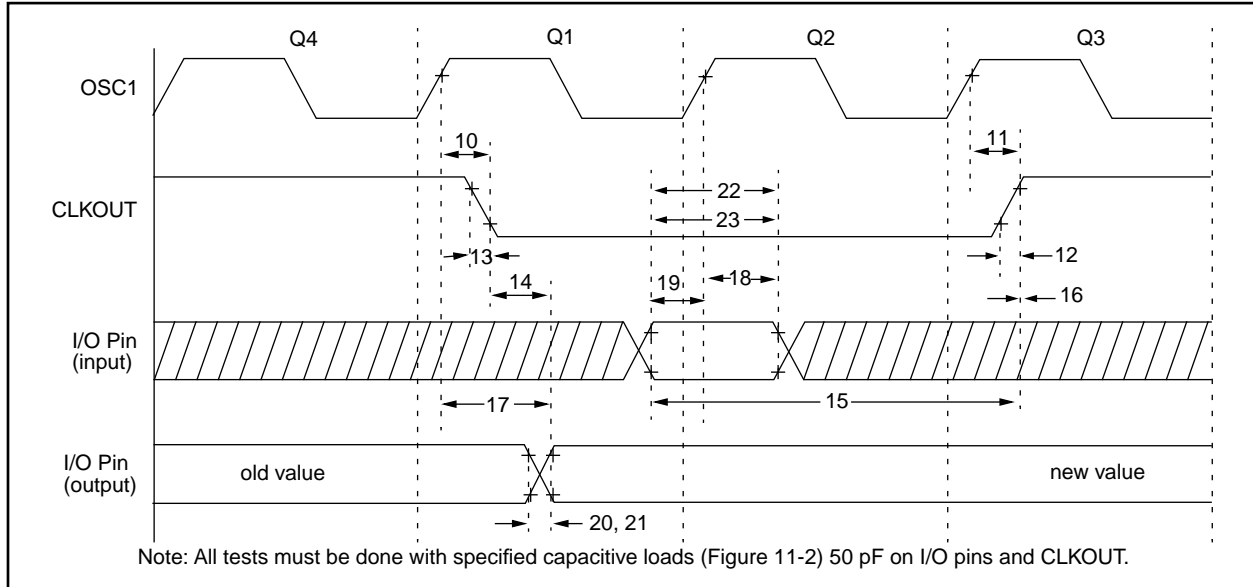

TABLE 11-4 CLKOUT AND I/O TIMING REQUIREMENTS

Parameter No.	Sym	Characteristic	Min	Typ†	Max	Units	Conditions
10	TosH2ckL	OSC1↑ to CLKOUT↓	—	15	30 *	ns	Note 1
10A			—	15	120 *	ns	Note 1
11	TosH2ckH	OSC1↑ to CLKOUT↑	—	15	30 *	ns	Note 1
11A			—	15	120 *	ns	Note 1
12	TckR	CLKOUT rise time	—	15	30 *	ns	Note 1
12A			—	15	100 *	ns	Note 1
13	TckF	CLKOUT fall time	—	15	30 *	ns	Note 1
13A			—	15	100 *	ns	Note 1
14	TckL2ioV	CLKOUT ↓ to Port out valid	—	—	0.5TCY + 20 *	ns	Note 1
15	TioV2ckH	Port in valid before CLKOUT ↑	0.30TCY + 30 *	—	—	ns	Note 1
			0.30TCY + 80 *	—	—	ns	Note 1
16	TckH2iol	Port in hold after CLKOUT ↑	0 *	—	—	ns	Note 1
17	TosH2ioV	OSC1↑ (Q1 cycle) to Port out valid	—	—	125 *	ns	
			—	—	250 *	ns	
18	TosH2iol	OSC1↑ (Q2 cycle) to Port input invalid (I/O in hold time)	TBD	—	—	ns	
19	TioV2osH	Port input valid to OSC1↑ (I/O in setup time)	TBD	—	—	ns	
20	TioR	Port output rise time	—	10	25 *	ns	
20A			—	10	60 *	ns	
21	TioF	Port output fall time	—	10	25 *	ns	
21A			—	10	60 *	ns	
22	Tinp	INT pin high or low time	20 *	—	—	ns	
22A			55 *	—	—	ns	
23	Trbp	RB7:RB4 change INT high or low time	20 *	—	—	ns	
23A			55 *	—	—	ns	

* These parameters are characterized but not tested.

† Data in "Typ" column is at 5.0V, 25°C unless otherwise stated. These parameters are for design guidance only and are not tested.

Note 1: Measurements are taken in RC Mode where CLKOUT output is 4 x Tosc.

FIGURE 11-5: RESET, WATCHDOG TIMER, OSCILLATOR START-UP TIMER AND POWER-UP TIMER TIMING

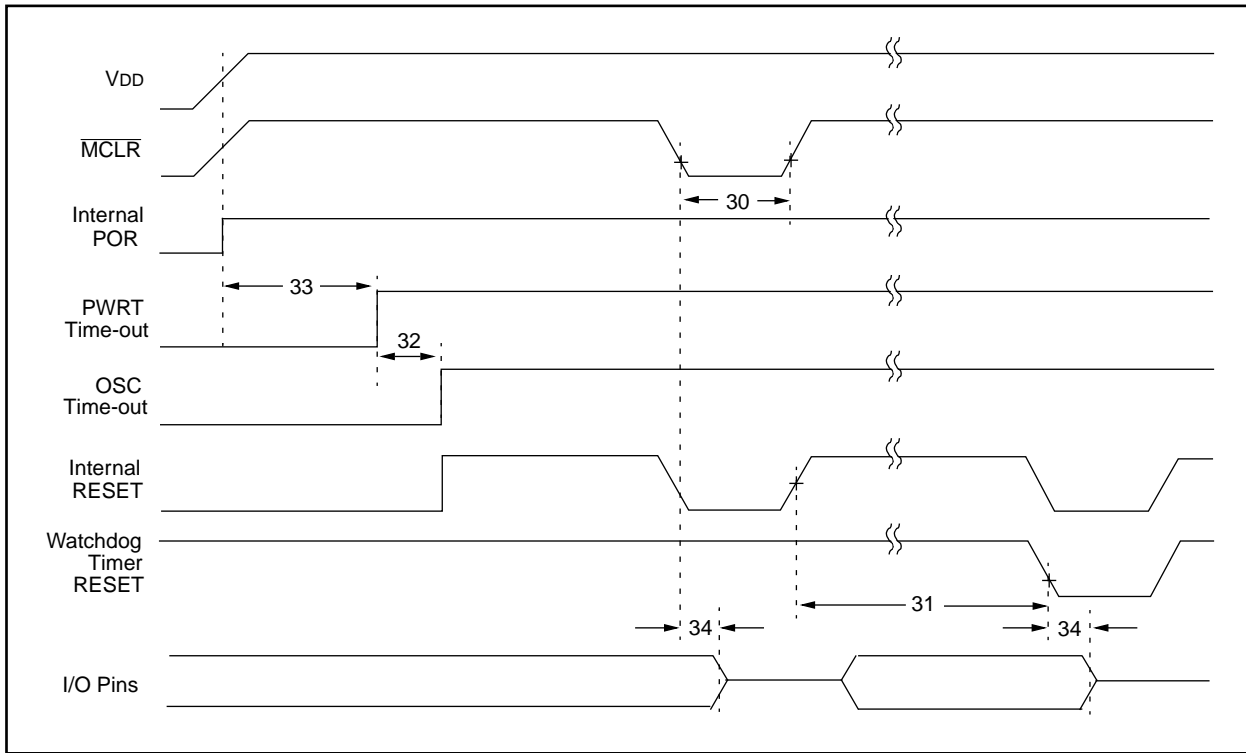

TABLE 11-5 RESET, WATCHDOG TIMER, OSCILLATOR START-UP TIMER AND POWER-UP TIMER REQUIREMENTS

Parameter No.	Sym	Characteristic	Min	Typ†	Max	Units	Conditions
30	Tmcl	MCLR Pulse Width (low)	350 *	—	—	ns	$2.0V \leq V_{DD} \leq 3.0V$
			150 *	—	—	ns	$3.0V \leq V_{DD} \leq 6.0V$
31	Twdt	Watchdog Timer Time-out Period (No Prescaler)	7 *	18	33 *	ms	$V_{DD} = 5V$
32	Tost	Oscillation Start-up Timer Period	—	$1024T_{OSC}$	—	ms	$T_{OSC} = OSC1$ period
33	Tpwrt	Power-up Timer Period	28 *	72	132 *	ms	$V_{DD} = 5.0V$
34	Tioz	I/O Hi-impedance from MCLR Low or reset	—	—	100 *	ns	

* These parameters are characterized but not tested.

† Data in "Typ" column is at 5.0V, 25°C unless otherwise stated. These parameters are for design guidance only and are not tested.

FIGURE 11-6: TIMER0 CLOCK TIMINGS

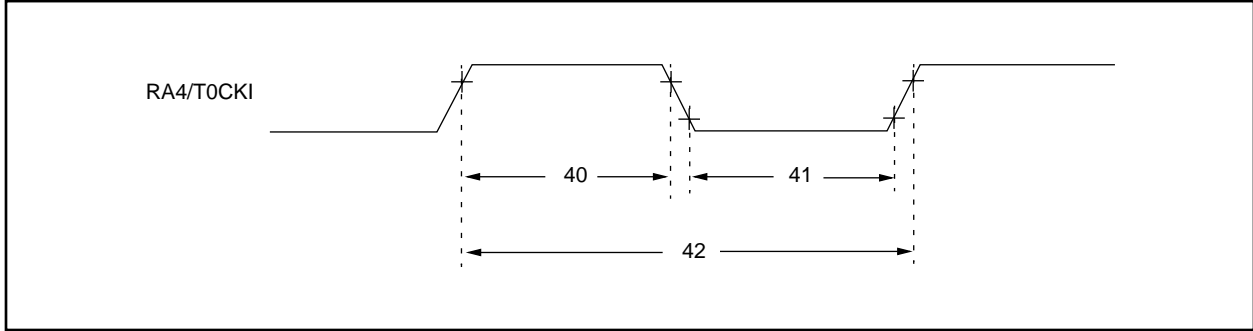

TABLE 11-6 TIMER0 CLOCK REQUIREMENTS

Parameter No.	Sym	Characteristic	Min	Typ†	Max	Units	Conditions
40	Tt0H	T0CKI High Pulse Width	No Prescaler	$0.5T_{CY} + 20^*$	—	—	ns
			With Prescaler	50 * 30 *	—	—	ns
41	Tt0L	T0CKI Low Pulse Width	No Prescaler	$0.5T_{CY} + 20^*$	—	—	ns
			With Prescaler	50 * 20 *	—	—	ns
42	Tt0P	T0CKI Period	$\frac{T_{CY} + 40^*}{N}$	—	—	ns	N = prescale value (2, 4, ..., 256)

* These parameters are characterized but not tested.

† Data in "Typ" column is at 5.0V, 25°C unless otherwise stated. These parameters are for design guidance only and are not tested.

PIC16C84

NOTES:

12.0 DC & AC CHARACTERISTICS GRAPHS/TABLES FOR PIC16C84

The graphs and tables provided in this section are for **design guidance** and are **not tested or guaranteed**.

In some graphs or tables, the data presented are **outside specified operating range** (i.e., outside specified V_{DD} range). This is for **information only** and devices are guaranteed to operate properly only within the specified range.

The data presented in this section is a **statistical summary** of data collected on units from different lots over a period of time and matrix samples. 'Typical' represents the mean of the distribution at 25°C, while 'max' or 'min' represents (mean + 3 σ) and (mean - 3 σ) respectively, where σ is standard deviation.

FIGURE 12-1: TYPICAL RC OSCILLATOR FREQUENCY vs. TEMPERATURE

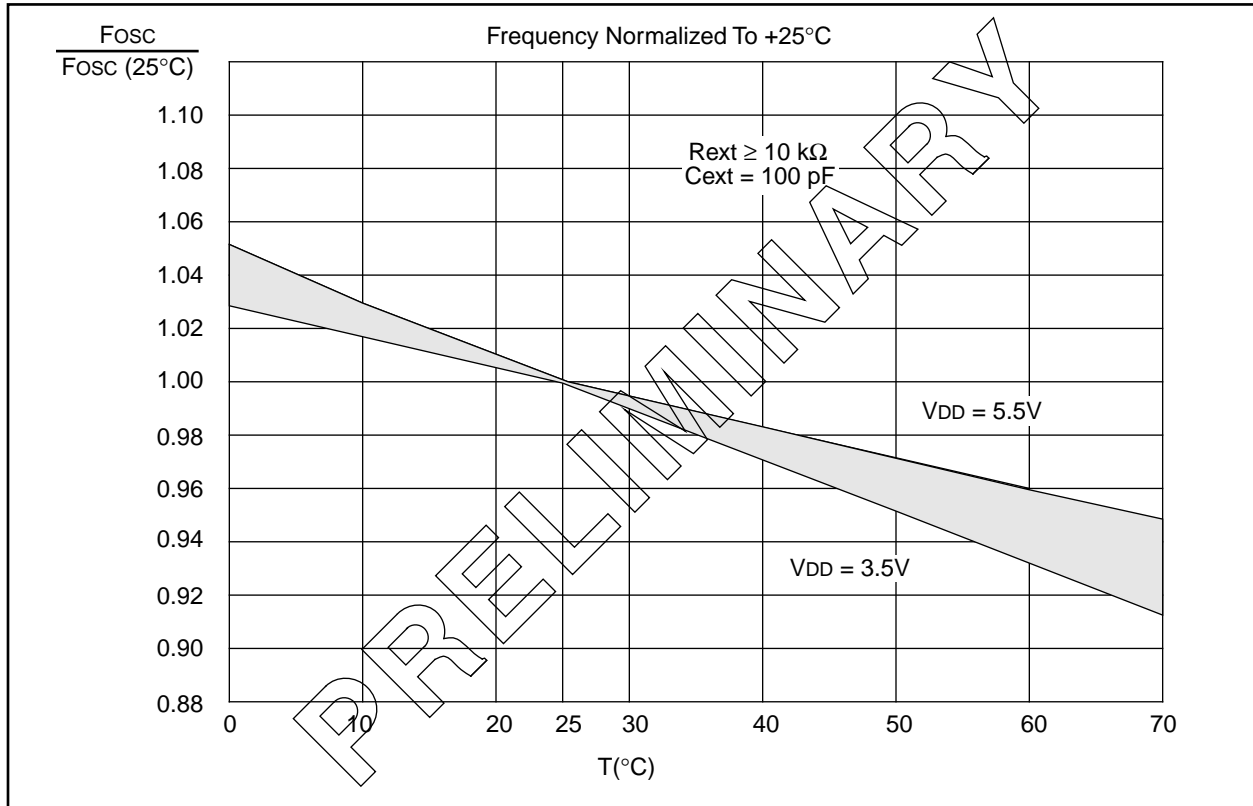

TABLE 12-1 RC OSCILLATOR FREQUENCIES *

Cext	Rext	Average Fosc @ 5V, 25°C	
		Average Fosc	Percentage Variation
20 pF	3.3k	4.68 MHz	± 27%
	5.1k	3.94 MHz	± 25%
	10k	2.34 MHz	± 29%
	100k	250.16 kHz	± 33%
100 pF	3.3k	1.49 MHz	± 25%
	5.1k	1.12 MHz	± 25%
	10k	620.31 kHz	± 30%
	100k	90.25 kHz	± 26%
300 pF	3.3k	524.24 kHz	± 28%
	5.1k	415.52 kHz	± 30%
	10k	270.33 kHz	± 26%
	100k	25.37 kHz	± 25%

*Measured in PDIP Packages. The percentage variation indicated here is part to part variation due to normal process distribution. The variation indicated is ± 3 standard deviation from average value.

PIC16C84

FIGURE 12-2: TYPICAL RC OSCILLATOR FREQUENCY vs. VDD (Cext = 20 pF)

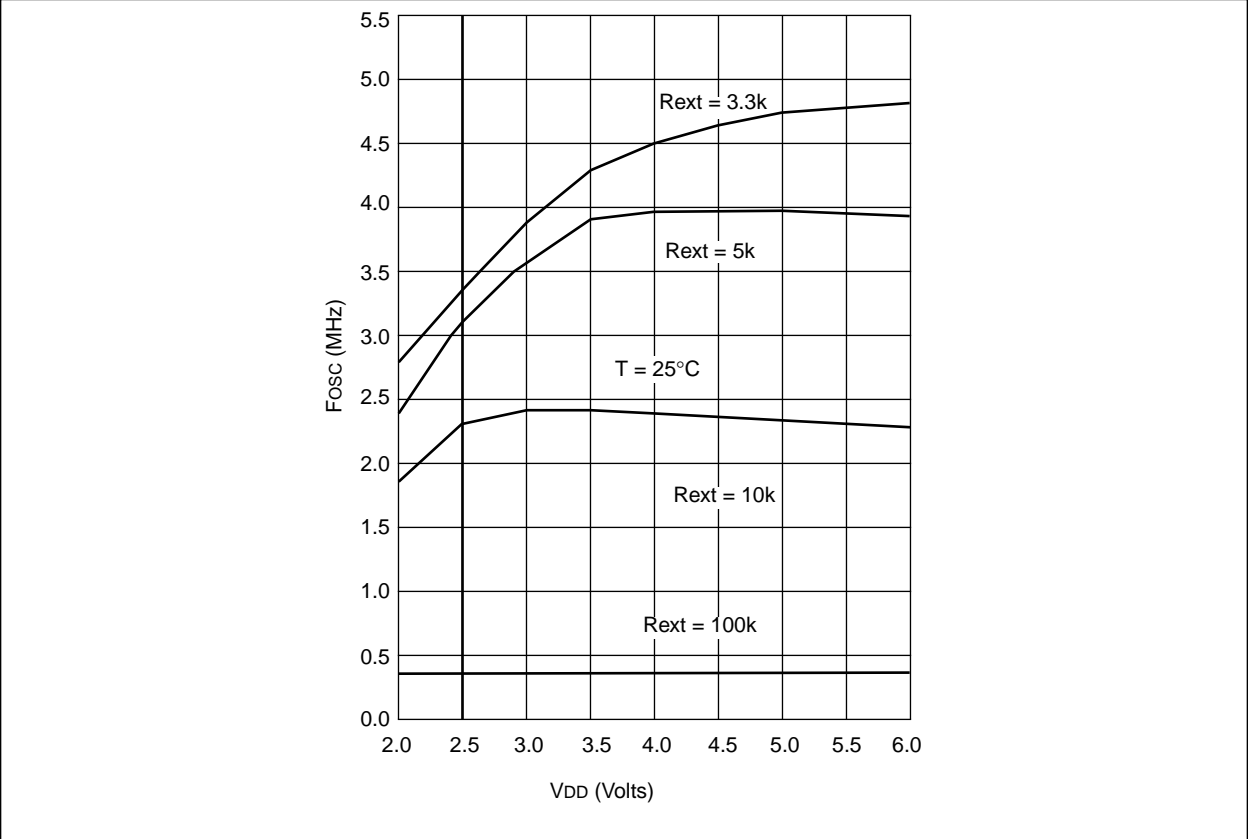

FIGURE 12-3: TYPICAL RC OSCILLATOR FREQUENCY vs. VDD (Cext = 100 pF)

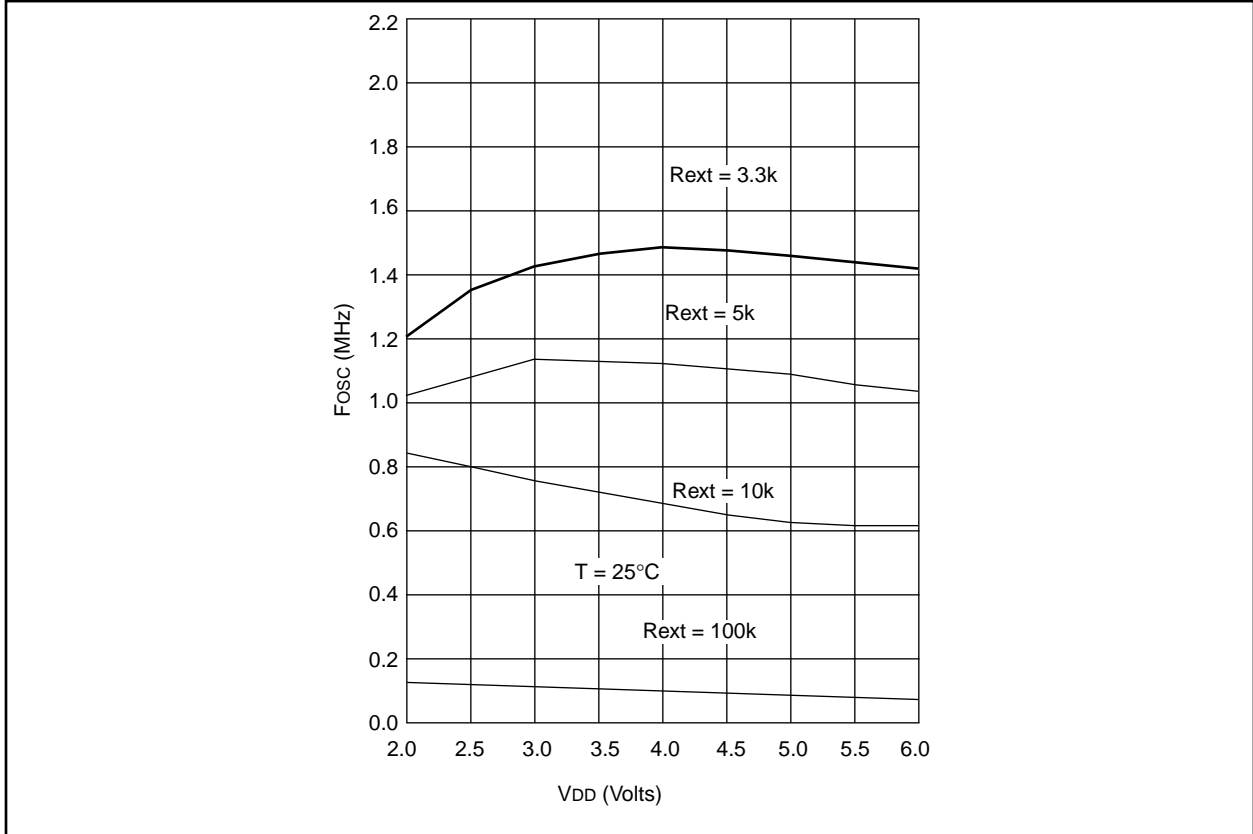
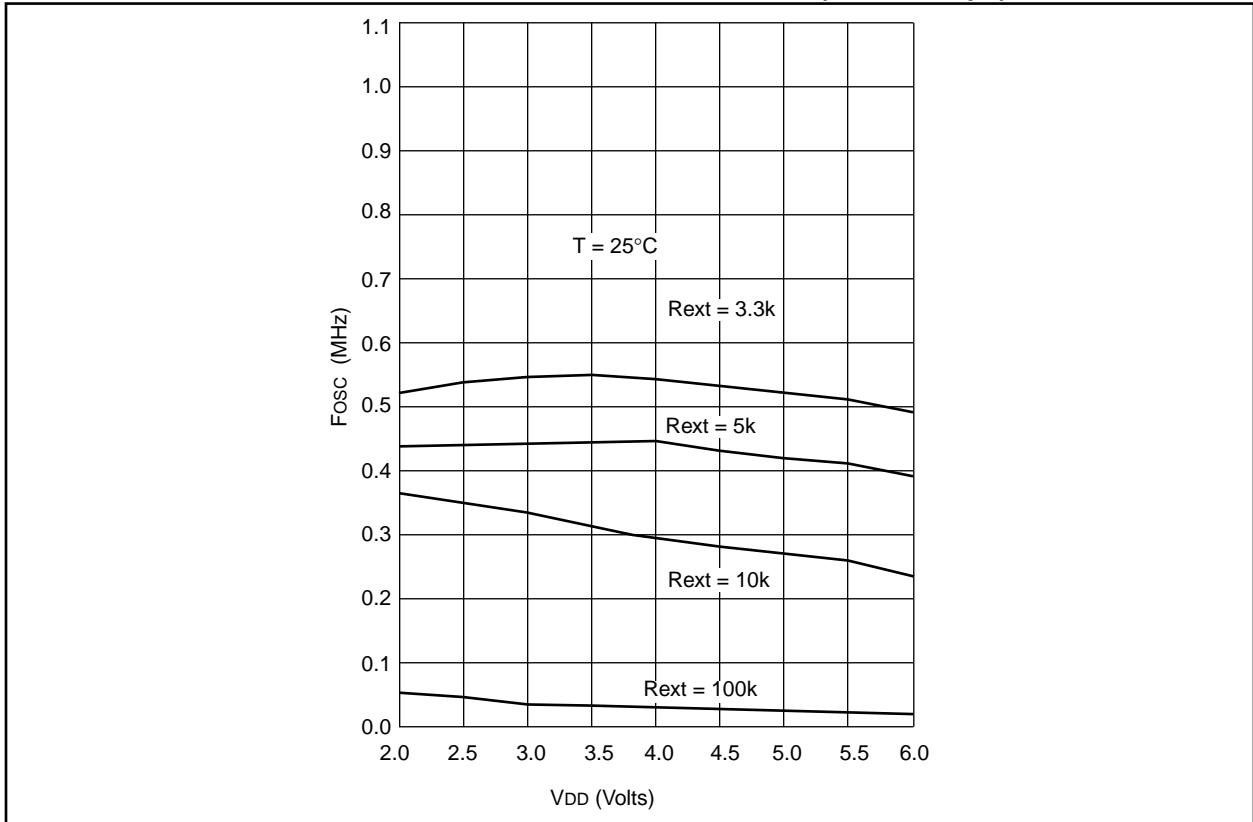

FIGURE 12-4: TYPICAL RC OSCILLATOR FREQUENCY vs. VDD (Cext = 300 pF)



PIC16C84

FIGURE 12-5: TYPICAL I_{PD} vs. V_{DD} WATCHDOG DISABLED (25°C)

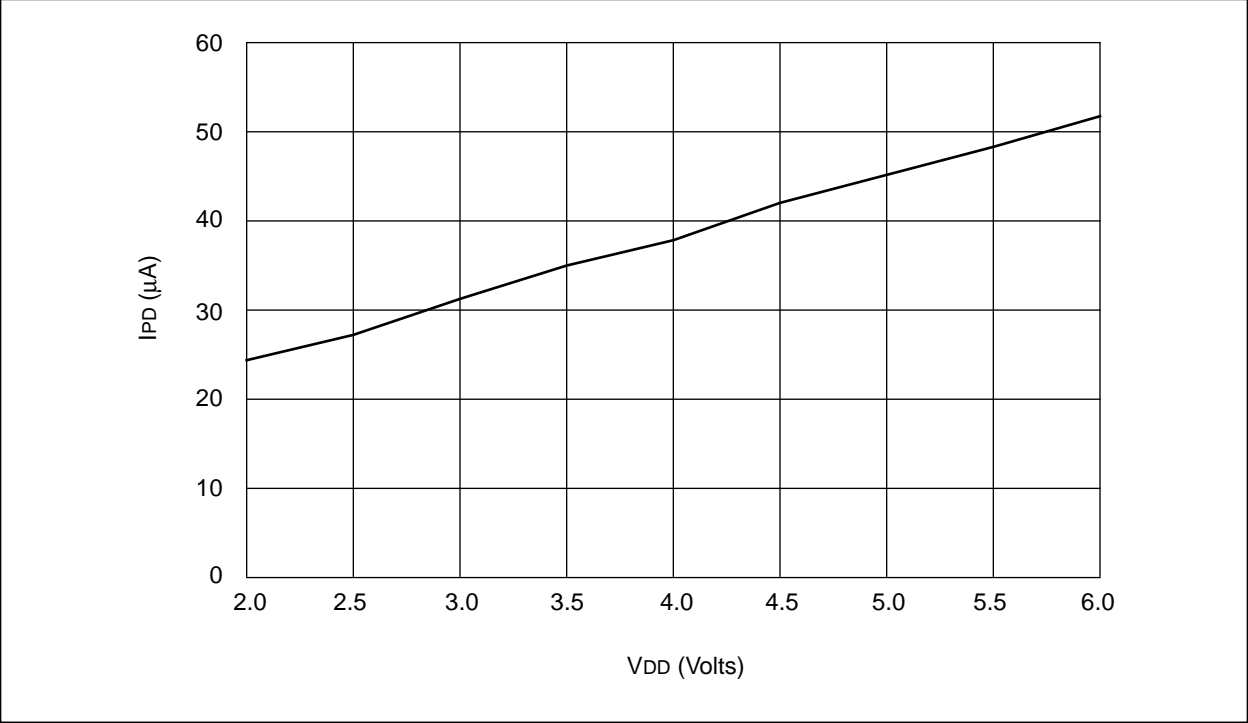

FIGURE 12-6: TYPICAL I_{PD} vs. V_{DD} WATCHDOG ENABLED (25°C)

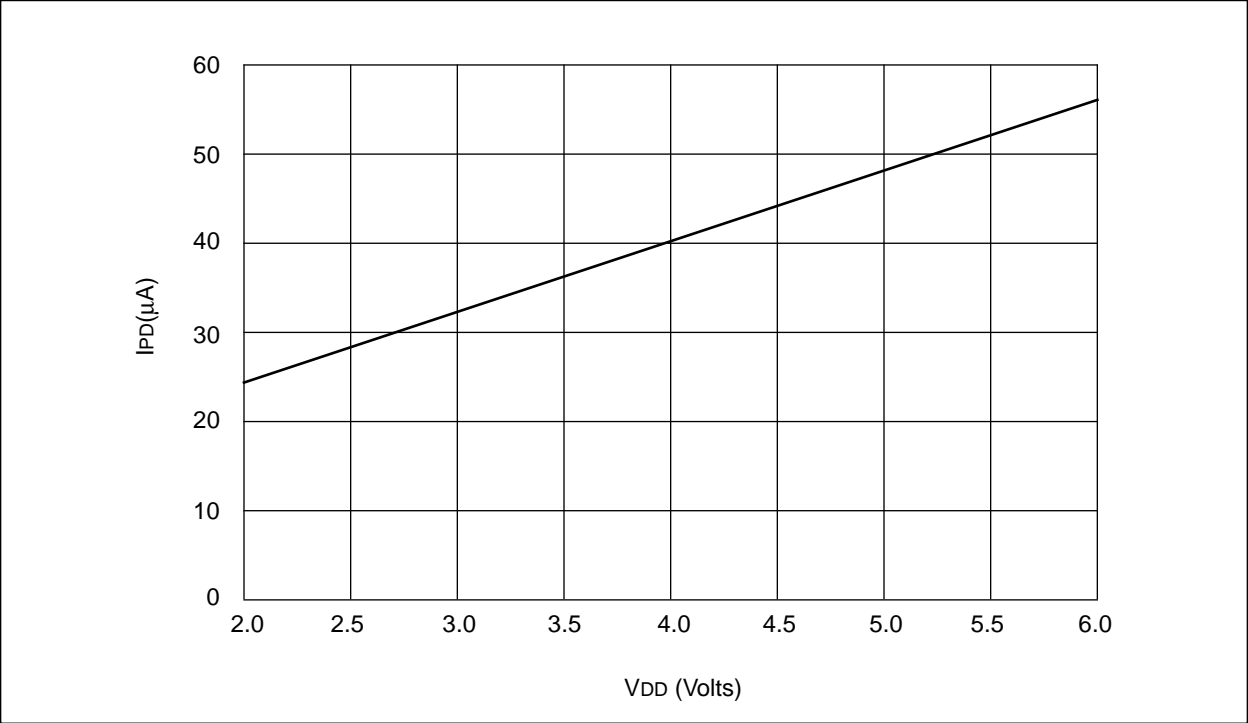

FIGURE 12-7: MAXIMUM IPD vs. VDD WATCHDOG DISABLED

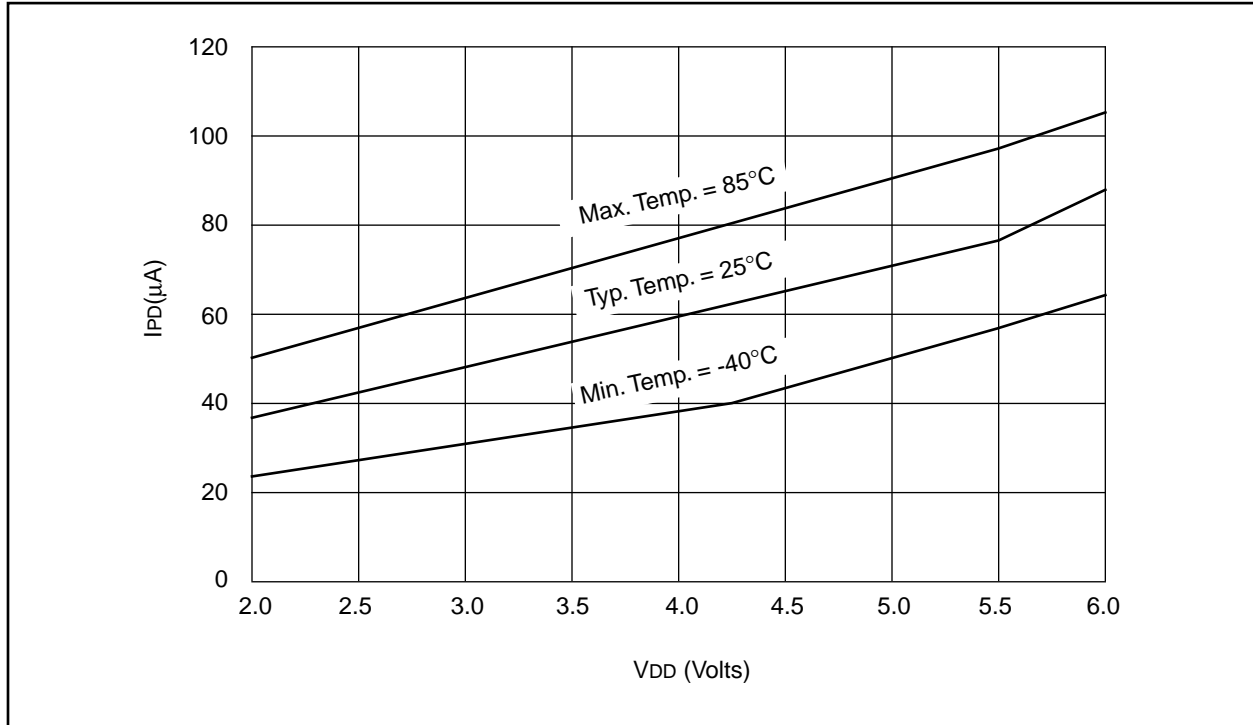
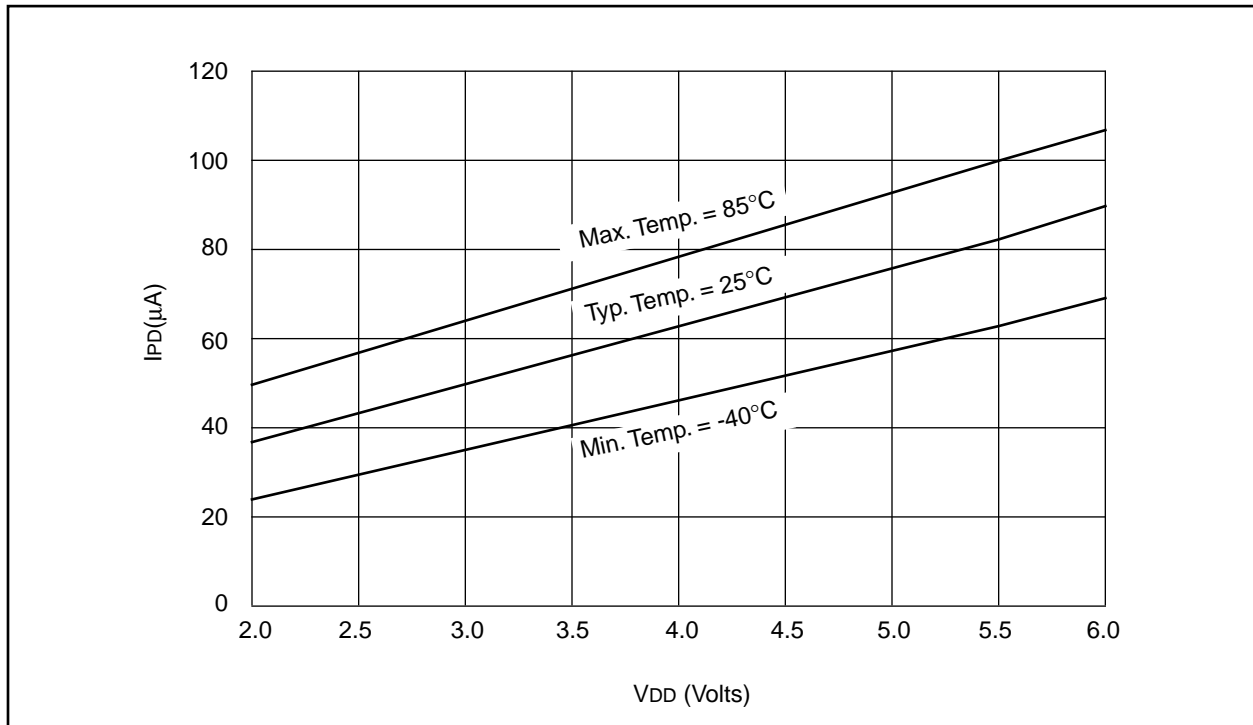

FIGURE 12-8: MAXIMUM IPD vs. VDD WATCHDOG ENABLED*



* IPD, with Watchdog Timer enabled, has two components: The leakage current which increases with higher temperature and the operating current of the Watchdog Timer logic which increases with lower temperature. At -40°C, the latter dominates explaining the apparently anomalous behavior.

FIGURE 12-9: V_{TH} (INPUT THRESHOLD VOLTAGE) OF I/O PINS vs. V_{DD}

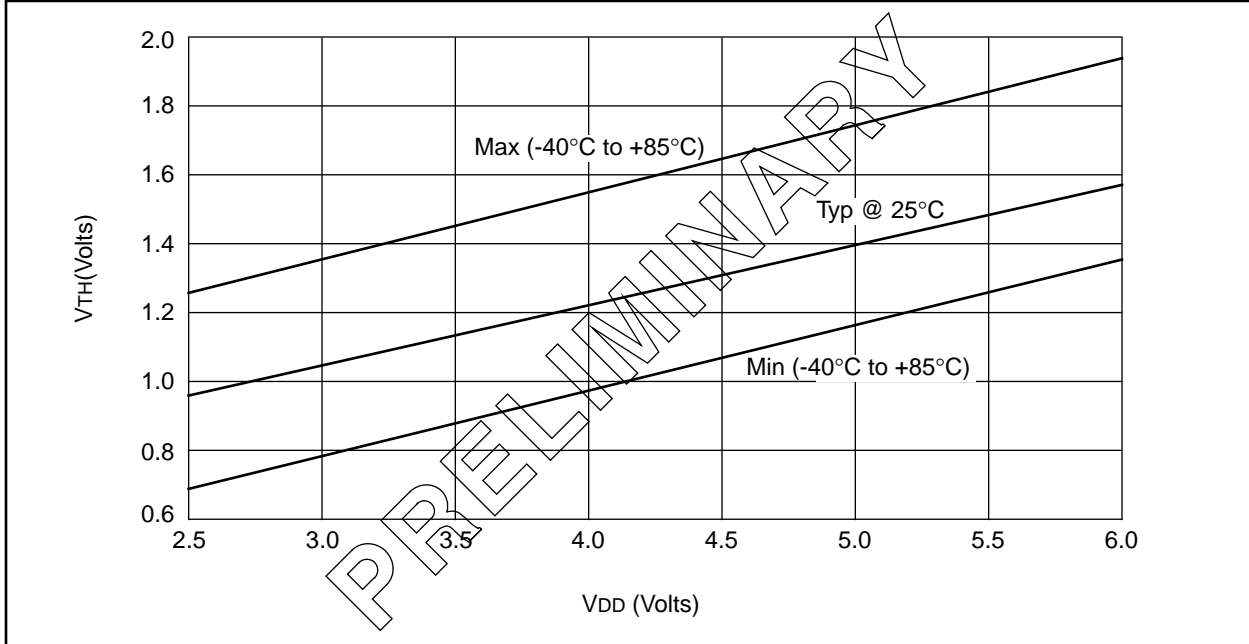

FIGURE 12-10: V_{TH} (INPUT THRESHOLD VOLTAGE) OF OSC1 INPUT (IN XT, HS, AND LP MODES) vs. V_{DD}

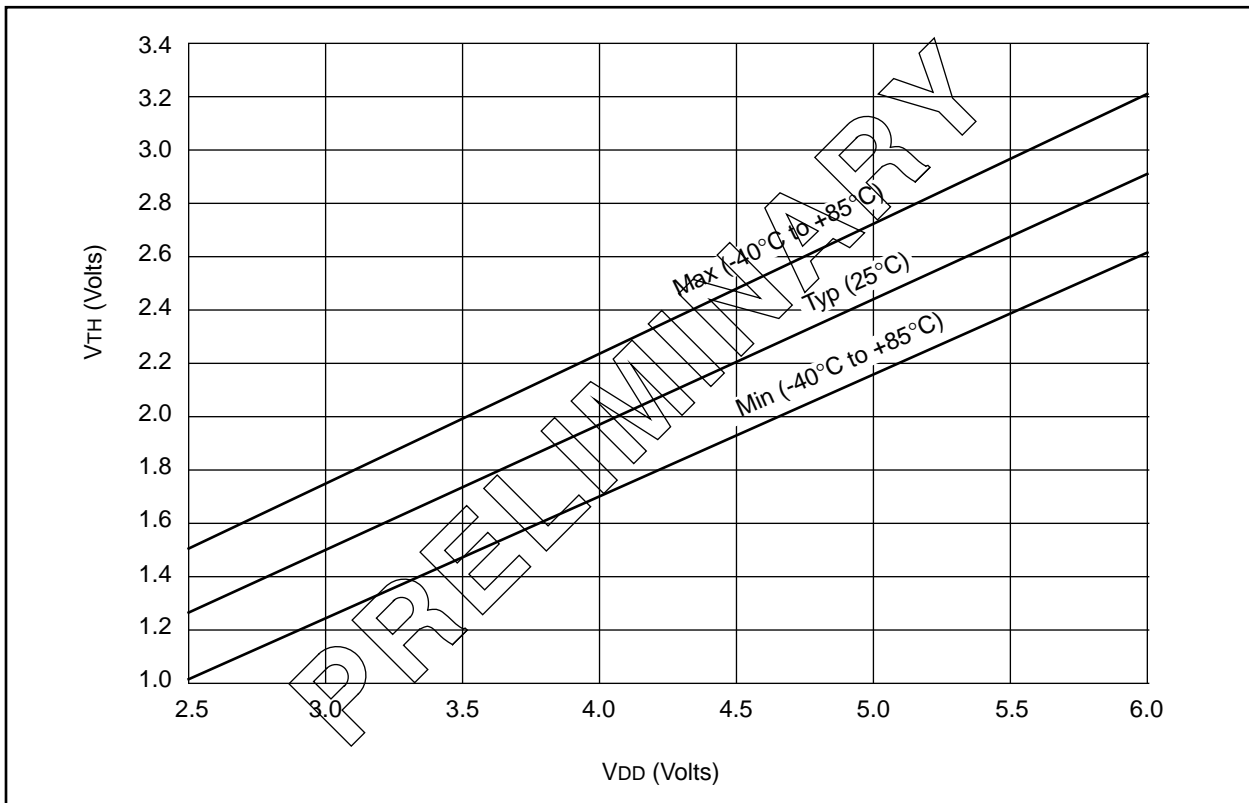
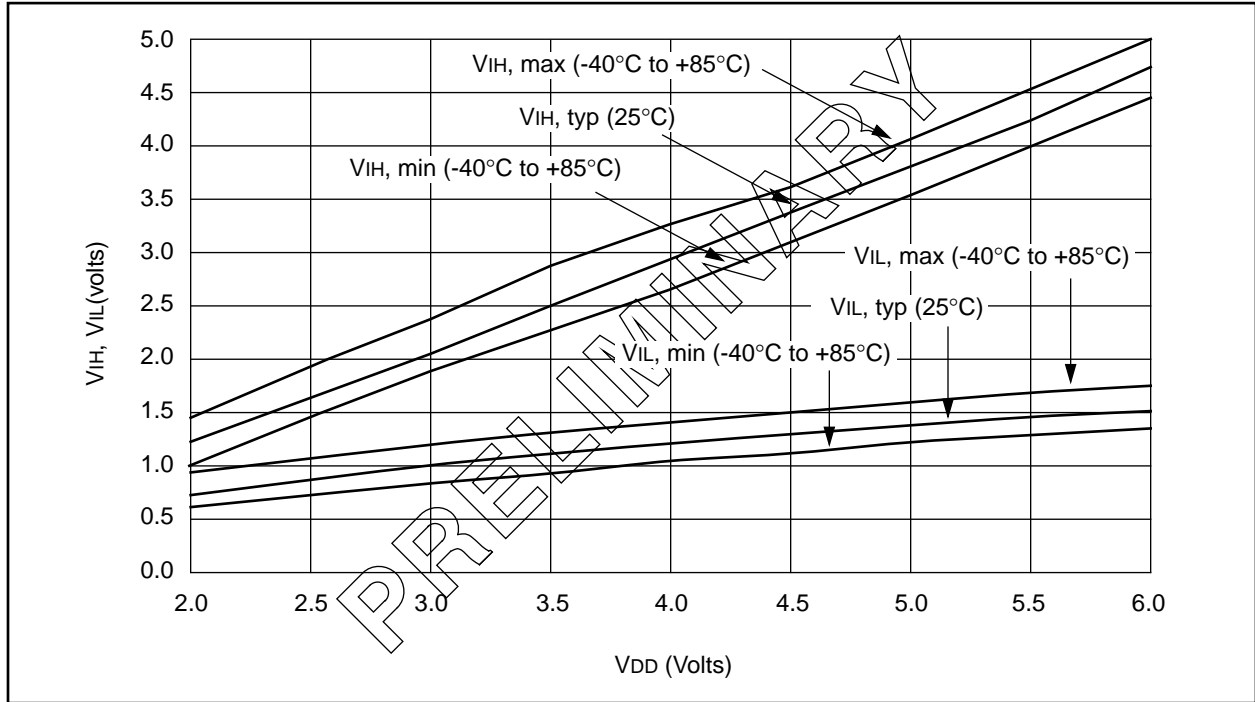

FIGURE 12-11: V_{IH} , V_{IL} OF MCLR, T0CKI and OSC1 (IN RC MODE) vs. V_{DD}



PIC16C84

FIGURE 12-12: TYPICAL I_{DD} vs. FREQ (EXT CLOCK, 25°C)

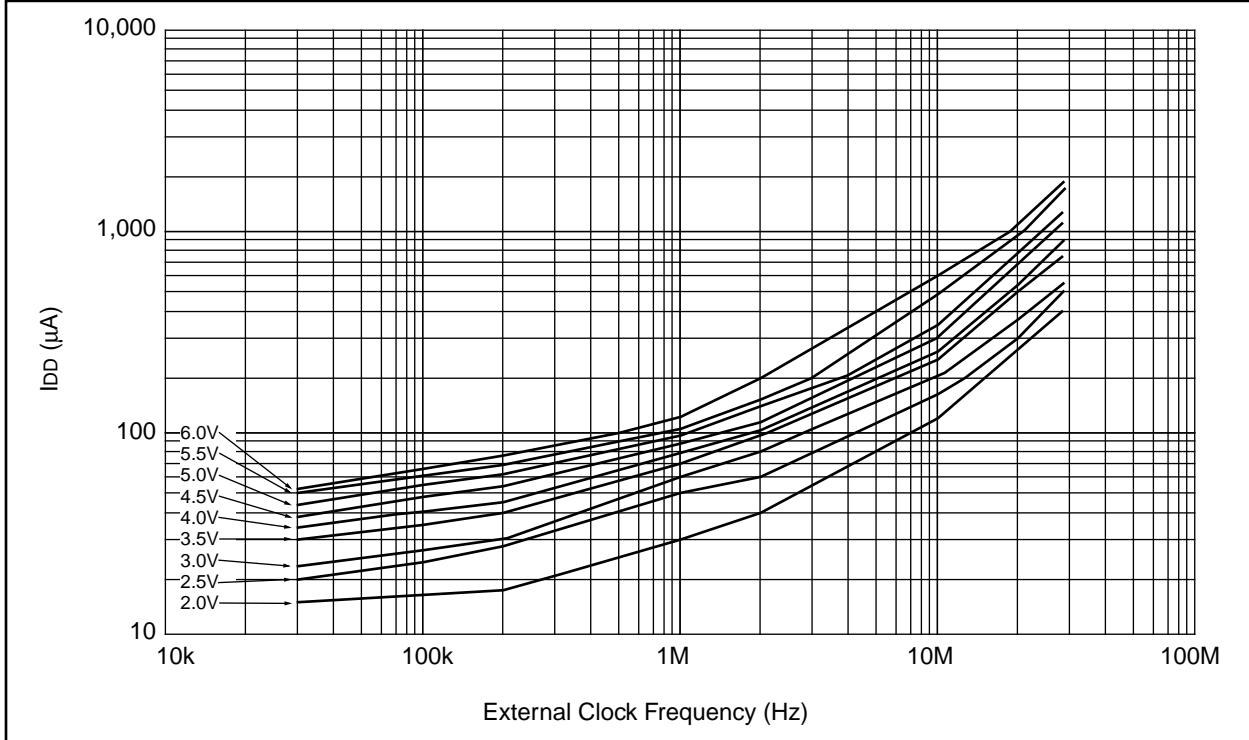

FIGURE 12-13: MAXIMUM I_{DD} vs. FREQ (EXT CLOCK, -40° TO +85°C)

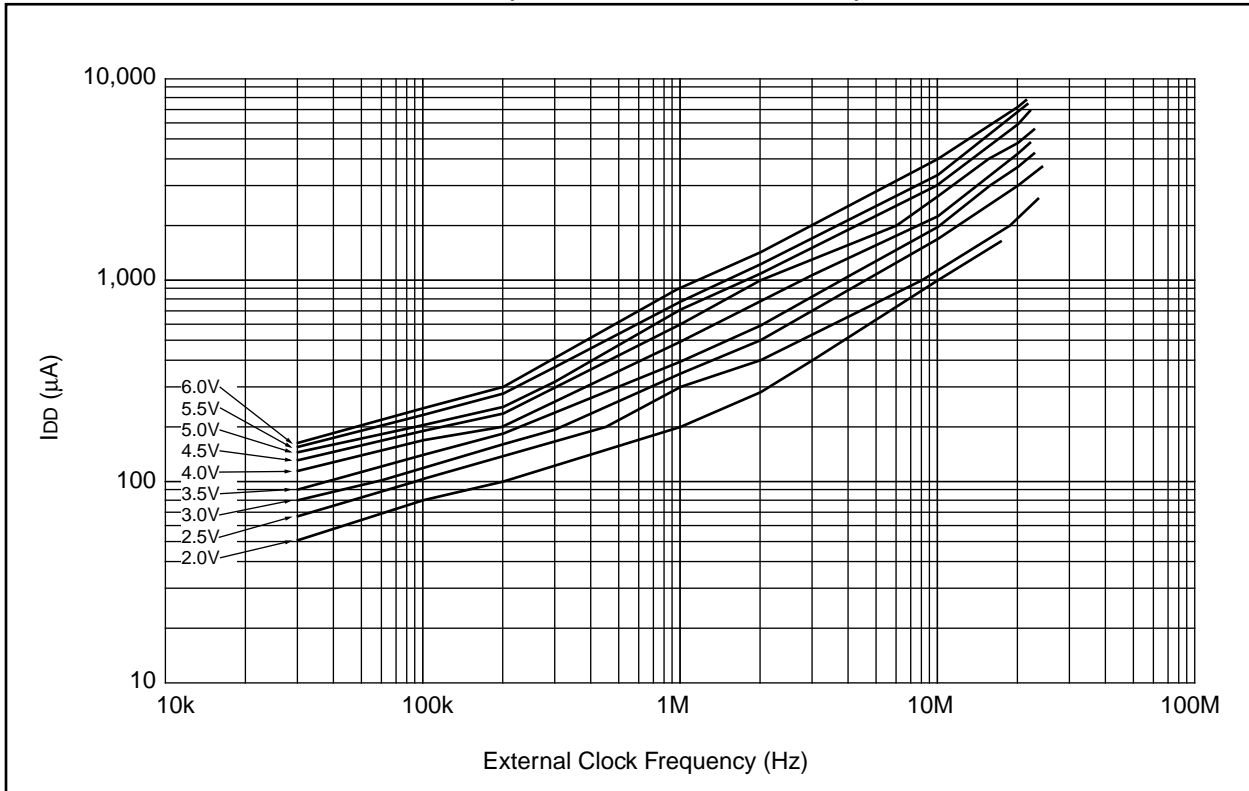

FIGURE 12-14: WDT TIME-OUT PERIOD vs. VDD

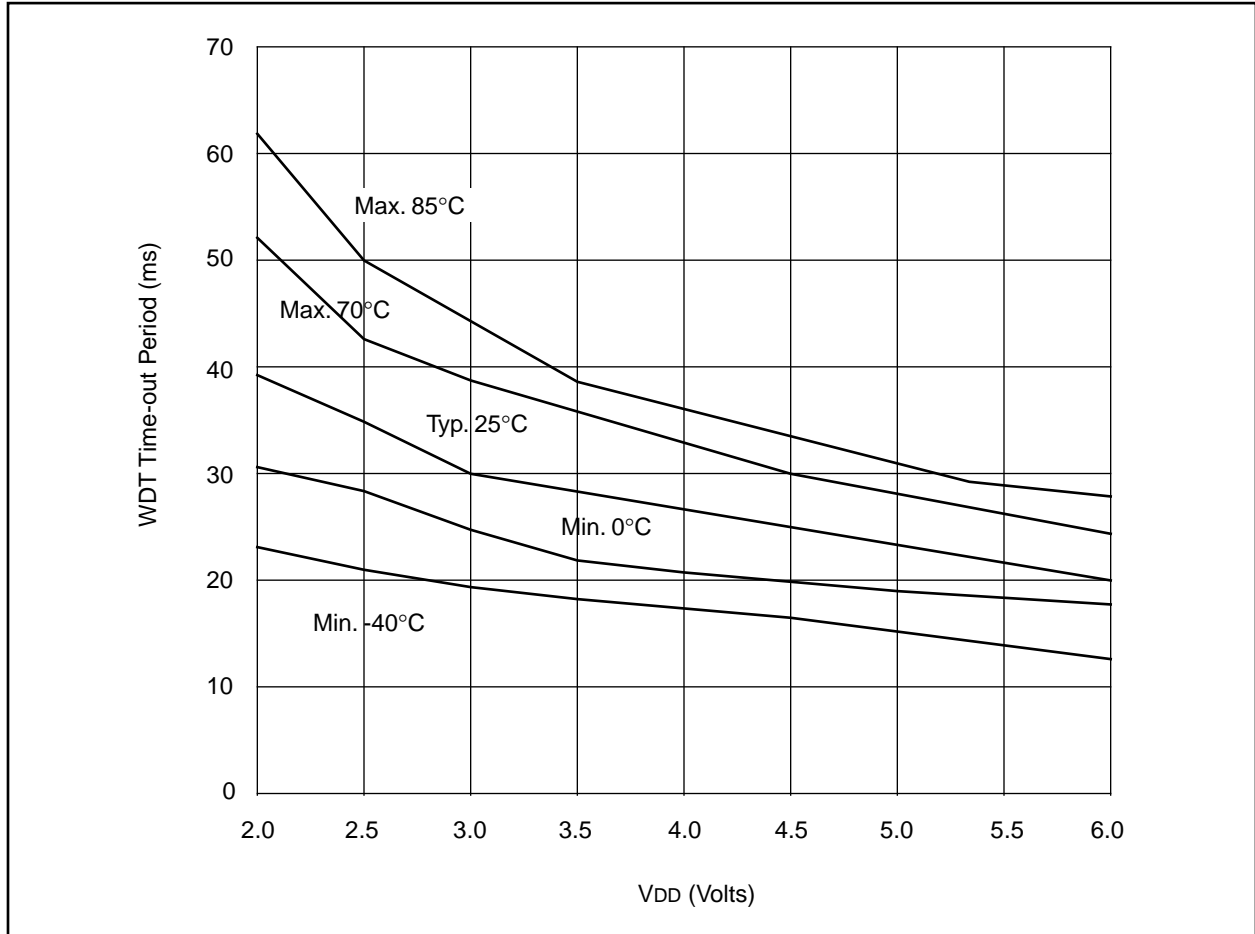
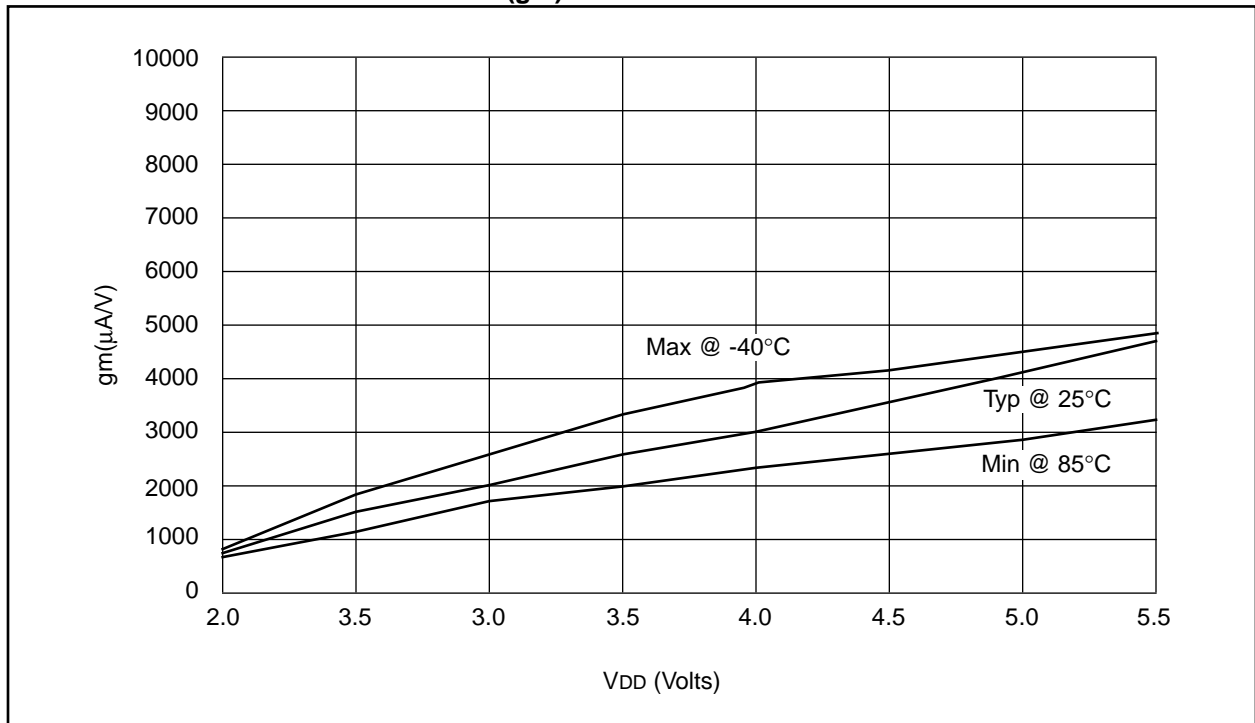

FIGURE 12-15: TRANSCONDUCTANCE (gm) OF HS OSCILLATOR vs. VDD



PIC16C84

FIGURE 12-16: TRANSCONDUCTANCE (gm) OF LP OSCILLATOR vs. VDD

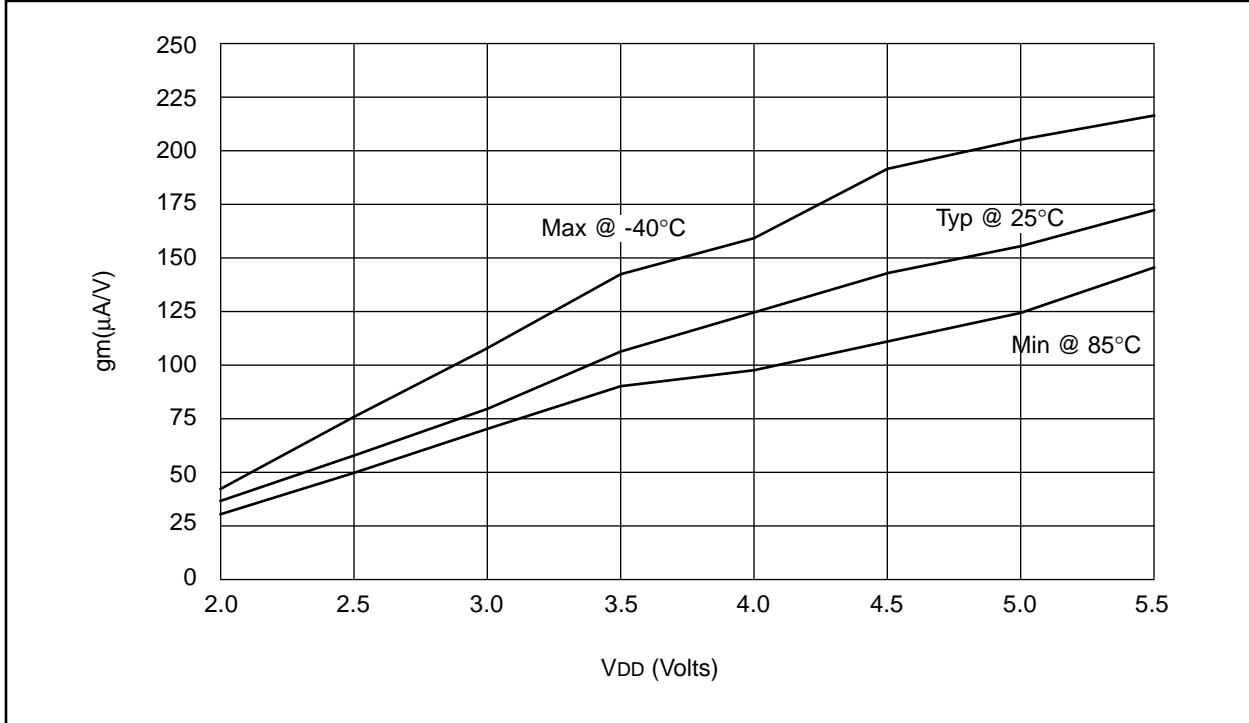

FIGURE 12-17: TRANSCONDUCTANCE (gm) OF XT OSCILLATOR vs. VDD

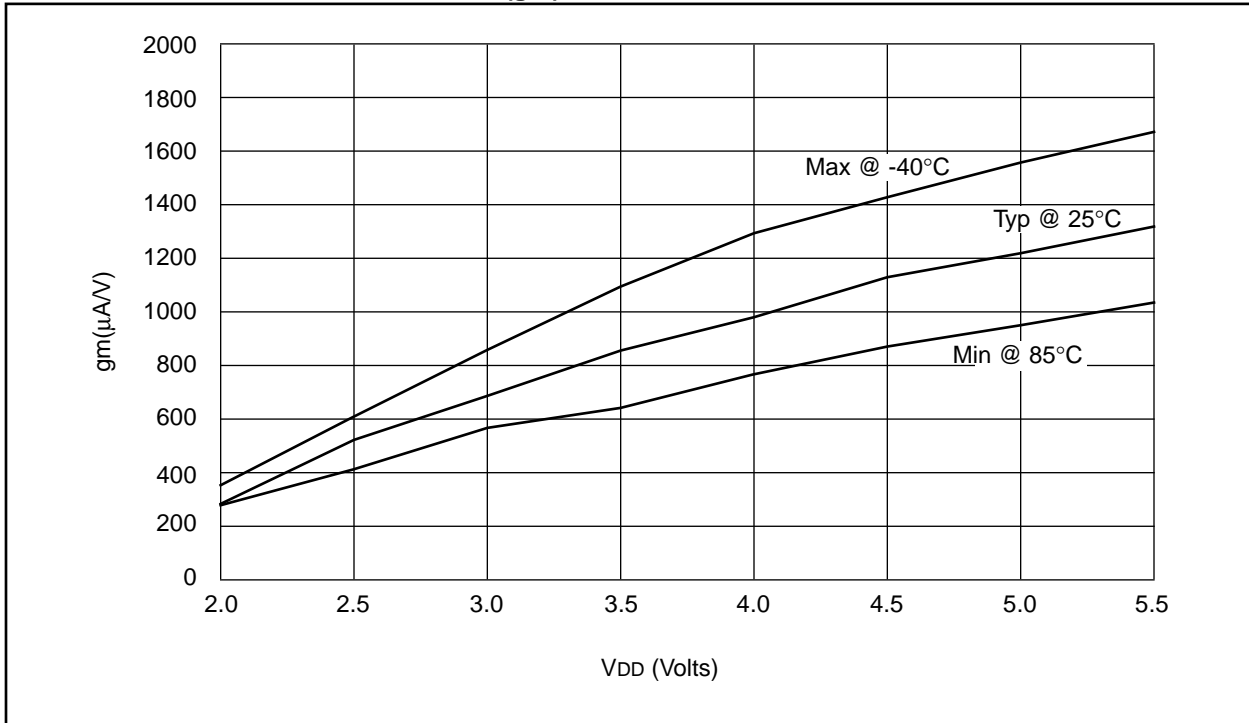

FIGURE 12-18: I_{OH} vs. V_{OH} , $V_{DD} = 3V$

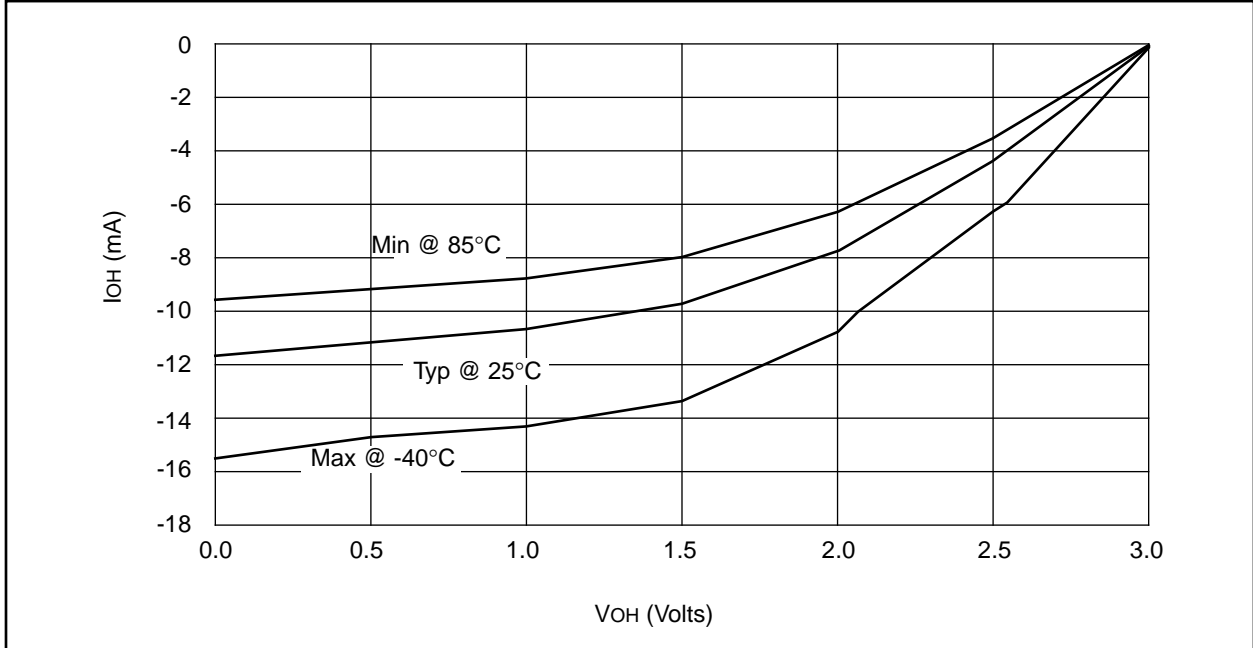
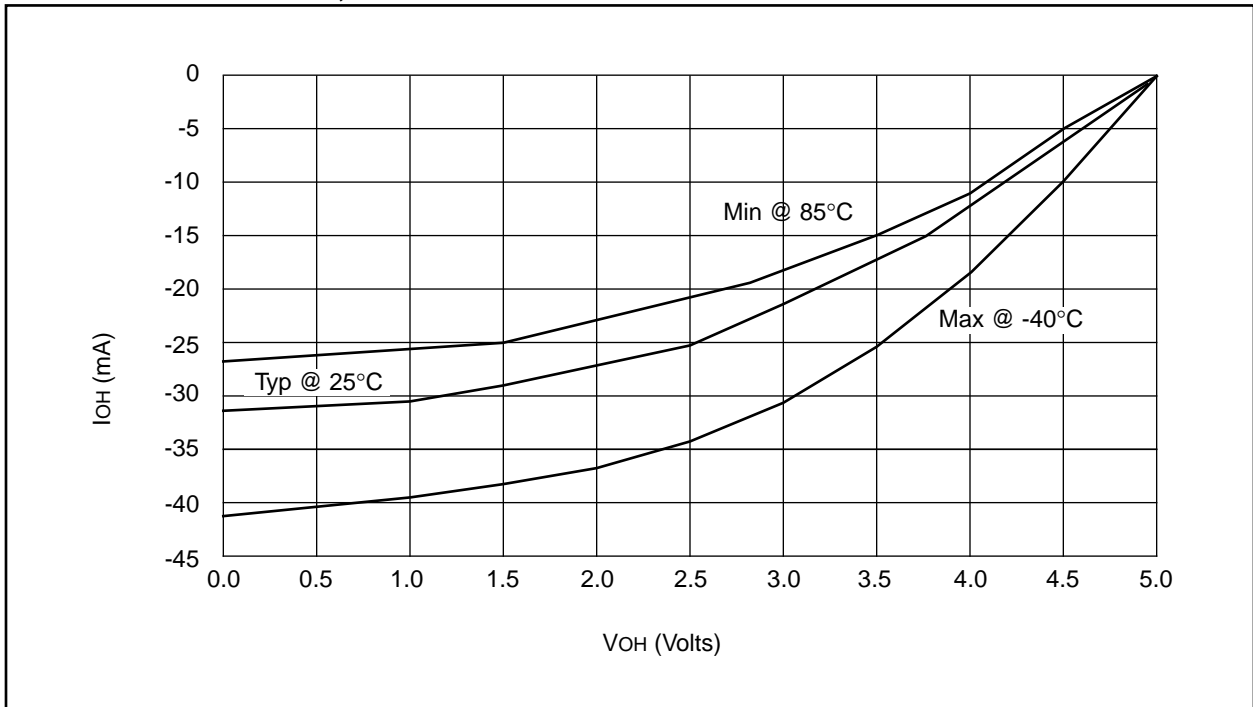

FIGURE 12-19: I_{OH} vs. V_{OH} , $V_{DD} = 5V$



PIC16C84

FIGURE 12-20: I_{OL} vs. V_{OL} , $V_{DD} = 3V$

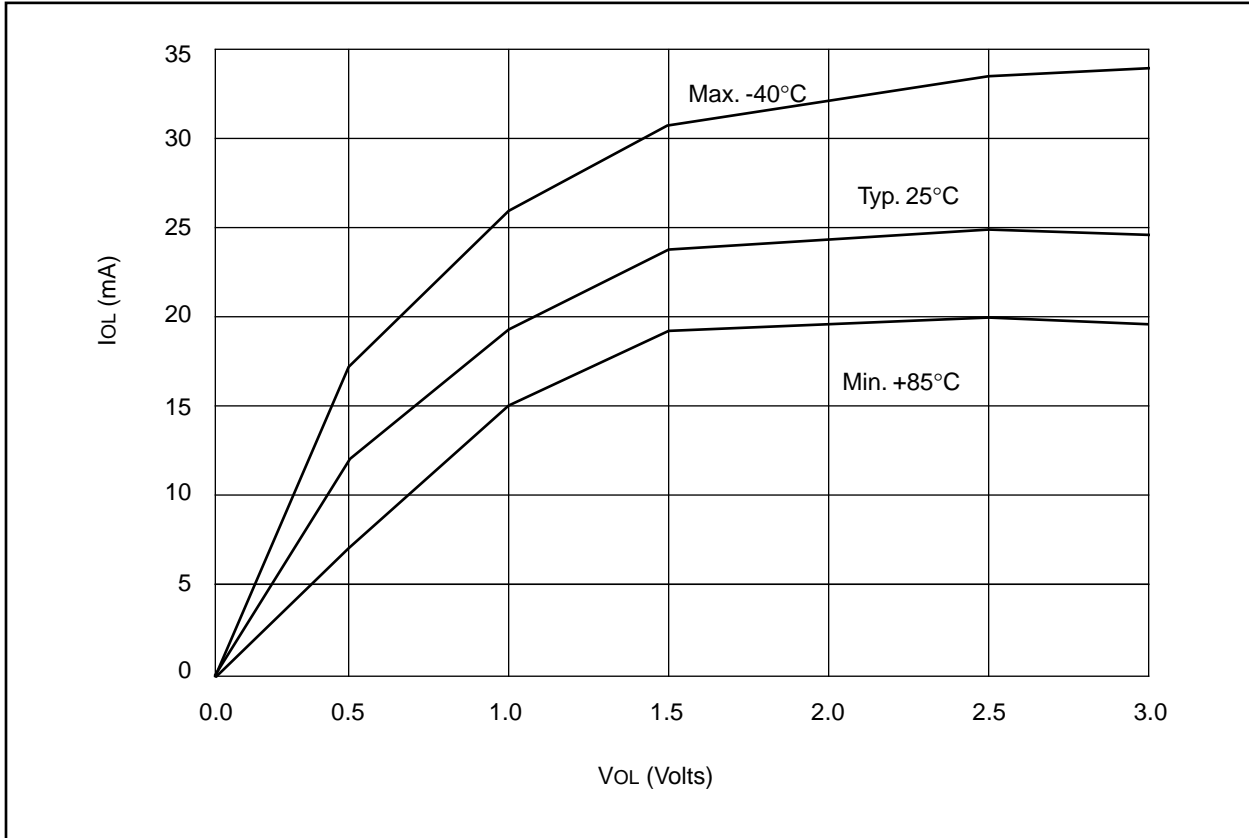

FIGURE 12-21: I_{OL} vs. V_{OL} , $V_{DD} = 5V$

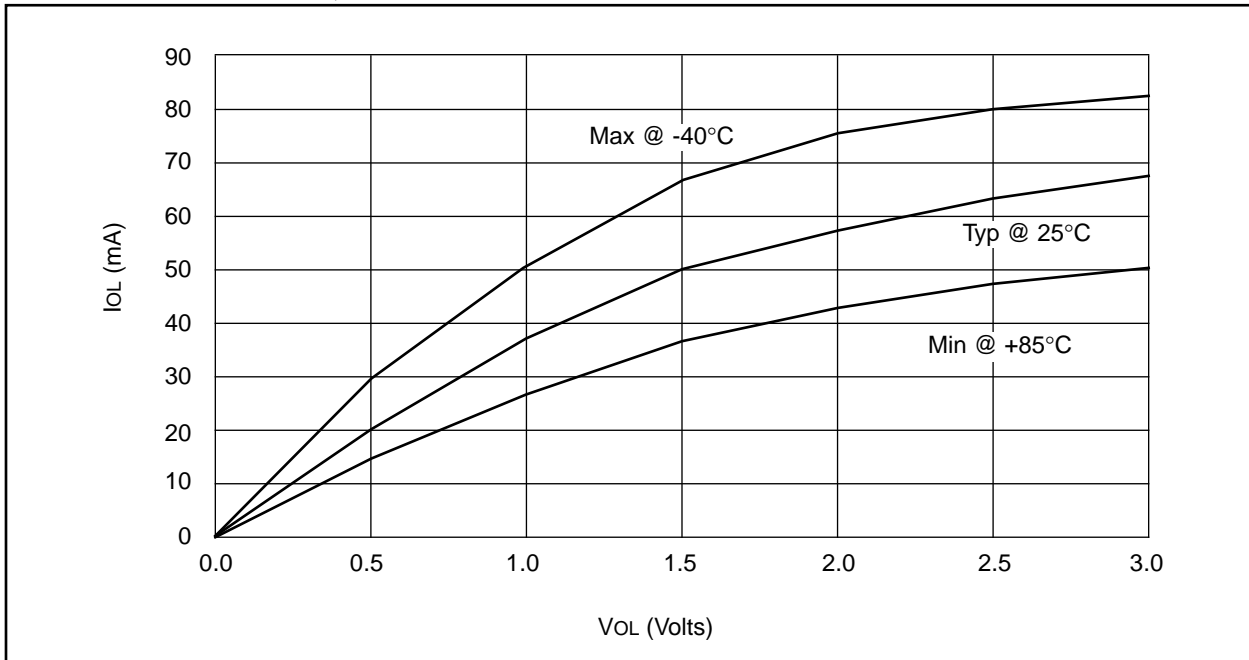

FIGURE 12-22: MAXIMUM DATA MEMORY ERASE/WRITE CYCLE TIME VS. VDD

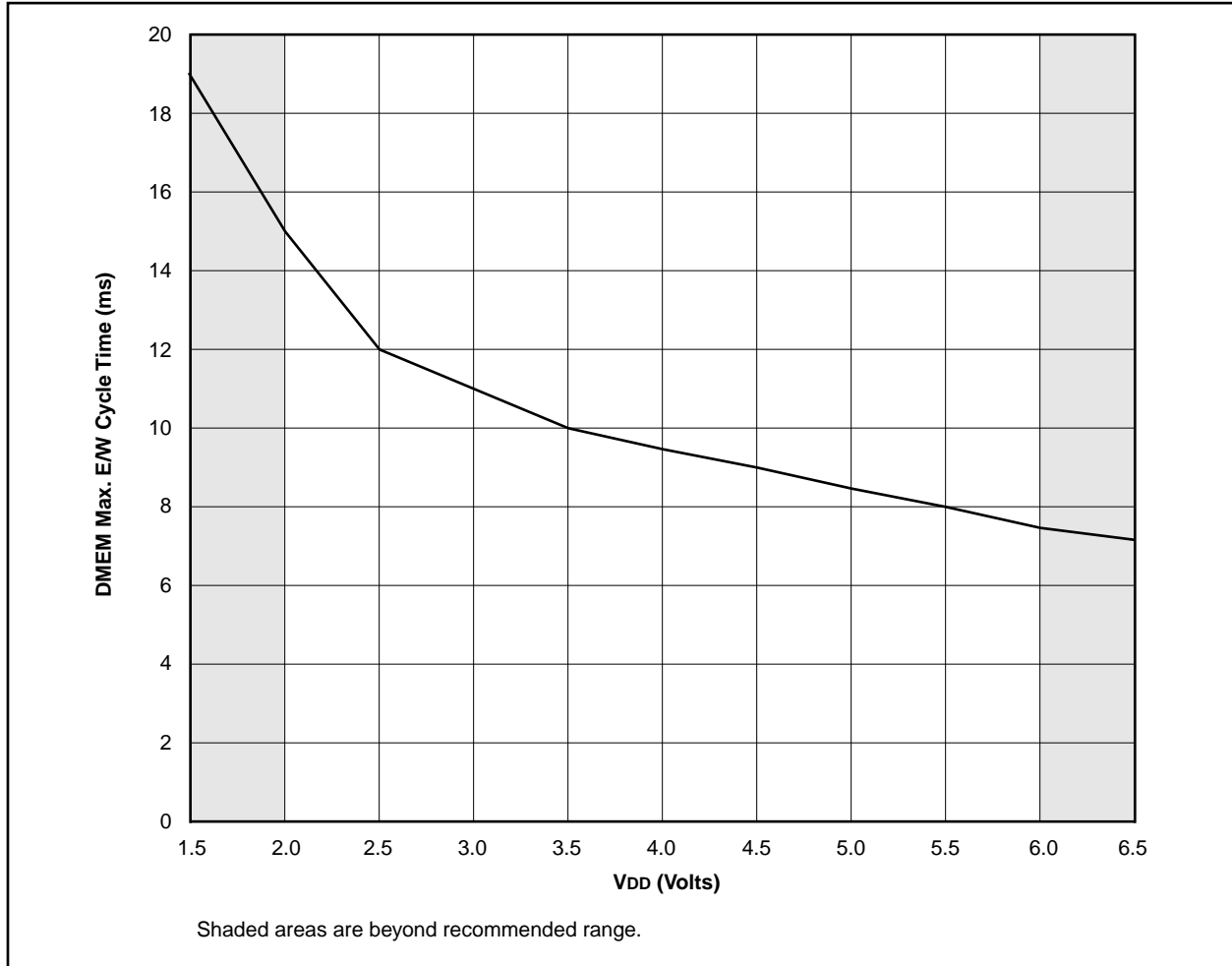

TABLE 12-2 INPUT CAPACITANCE*

Pin Name	Typical Capacitance (pF)	
	18L PDIP	18L SOIC
PORTA	5.0	4.3
PORTB	5.0	4.3
MCLR	17.0	17.0
OSC1/CLKIN	4.0	3.5
OSC2/CLKOUT	4.3	3.5
T0CKI	3.2	2.8

* All capacitance values are typical at 25°C. A part to part variation of $\pm 25\%$ (three standard deviations) should be taken into account.

PIC16C84

NOTES:

13.0 PACKAGING INFORMATION

13.1 K04-007 18-Lead Plastic Dual In-line (P) – 300 mil

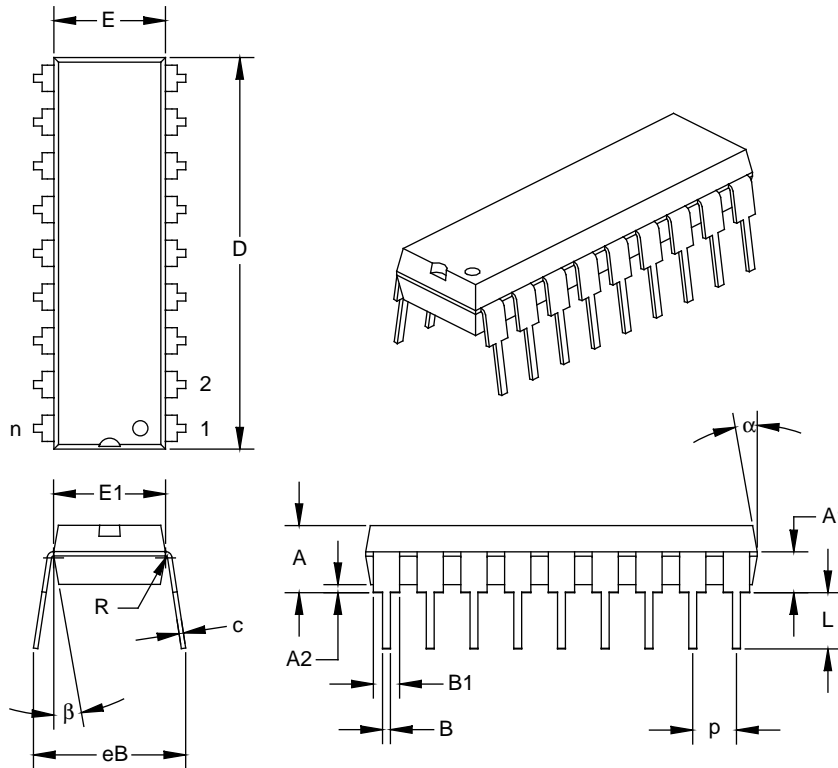

Units		INCHES*			MILLIMETERS		
		MIN	NOM	MAX	MIN	NOM	MAX
Dimension Limits			0.300			7.62	
PCB Row Spacing			0.300			7.62	
Number of Pins	n		18			18	
Pitch	p		0.100			2.54	
Lower Lead Width	B	0.013	0.018	0.023	0.33	0.46	0.58
Upper Lead Width	B1 [†]	0.055	0.060	0.065	1.40	1.52	1.65
Shoulder Radius	R	0.000	0.005	0.010	0.00	0.13	0.25
Lead Thickness	c	0.005	0.010	0.015	0.13	0.25	0.38
Top to Seating Plane	A	0.110	0.155	0.155	2.79	3.94	3.94
Top of Lead to Seating Plane	A1	0.075	0.095	0.115	1.91	2.41	2.92
Base to Seating Plane	A2	0.000	0.020	0.020	0.00	0.51	0.51
Tip to Seating Plane	L	0.125	0.130	0.135	3.18	3.30	3.43
Package Length	D [‡]	0.890	0.895	0.900	22.61	22.73	22.86
Molded Package Width	E [‡]	0.245	0.255	0.265	6.22	6.48	6.73
Radius to Radius Width	E1	0.230	0.250	0.270	5.84	6.35	6.86
Overall Row Spacing	eB	0.310	0.349	0.387	7.87	8.85	9.83
Mold Draft Angle Top	α	5	10	15	5	10	15
Mold Draft Angle Bottom	β	5	10	15	5	10	15

* Controlling Parameter.

[†] Dimension "B1" does not include dam-bar protrusions. Dam-bar protrusions shall not exceed 0.003" (0.076 mm) per side or 0.006" (0.152 mm) more than dimension "B1."

[‡] Dimensions "D" and "E" do not include mold flash or protrusions. Mold flash or protrusions shall not exceed 0.010" (0.254 mm) per side or 0.020" (0.508 mm) more than dimensions "D" or "E."

PIC16C84

13.2 K04-051 18-Lead Plastic Small Outline (SO) – Wide, 300 mil

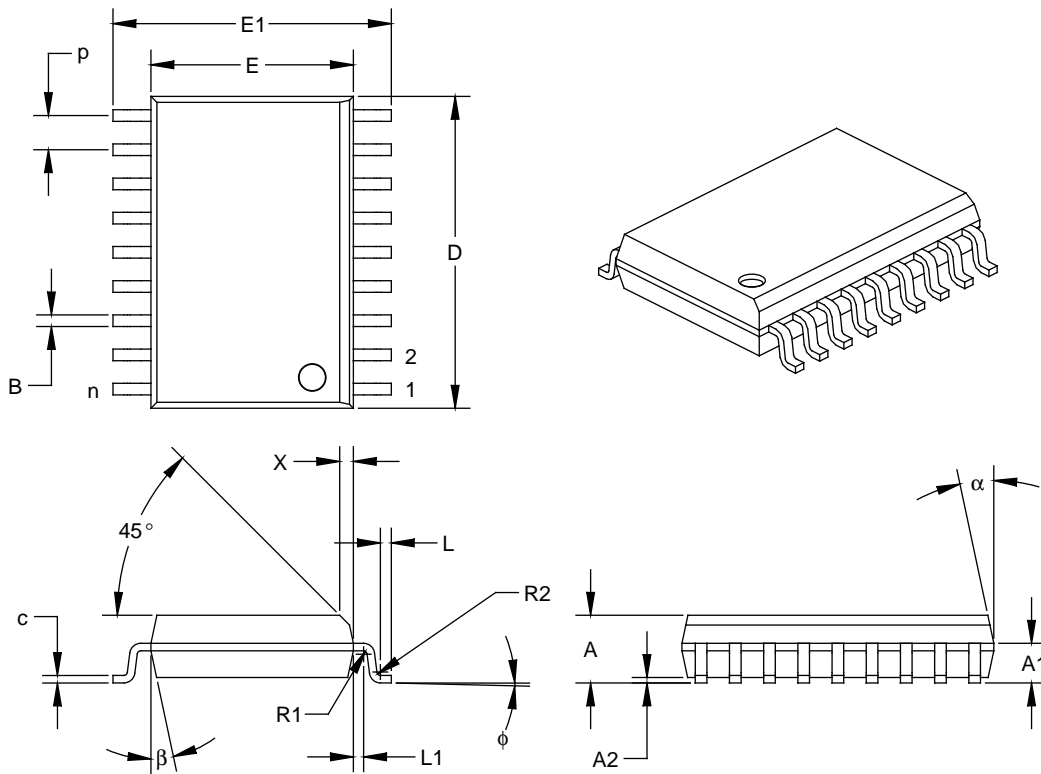

Units	Dimension Limits	INCHES*			MILLIMETERS			
		MIN	NOM	MAX	MIN	NOM	MAX	
	Pitch	p	0.050			1.27		
	Number of Pins	n	18			18		
	Overall Pack. Height	A	0.093	0.099	0.104	2.36	2.50	2.64
	Shoulder Height	A1	0.048	0.058	0.068	1.22	1.47	1.73
	Standoff	A2	0.004	0.008	0.011	0.10	0.19	0.28
	Molded Package Length	D [‡]	0.450	0.456	0.462	11.43	11.58	11.73
	Molded Package Width	E [‡]	0.292	0.296	0.299	7.42	7.51	7.59
	Outside Dimension	E1	0.394	0.407	0.419	10.01	10.33	10.64
	Chamfer Distance	X	0.010	0.020	0.029	0.25	0.50	0.74
	Shoulder Radius	R1	0.005	0.005	0.010	0.13	0.13	0.25
	Gull Wing Radius	R2	0.005	0.005	0.010	0.13	0.13	0.25
	Foot Length	L	0.011	0.016	0.021	0.28	0.41	0.53
	Foot Angle	φ	0	4	8	0	4	8
	Radius Centerline	L1	0.010	0.015	0.020	0.25	0.38	0.51
	Lead Thickness	c	0.009	0.011	0.012	0.23	0.27	0.30
	Lower Lead Width	B [†]	0.014	0.017	0.019	0.36	0.42	0.48
	Mold Draft Angle Top	α	0	12	15	0	12	15
	Mold Draft Angle Bottom	β	0	12	15	0	12	15

* Controlling Parameter.

† Dimension "B" does not include dam-bar protrusions. Dam-bar protrusions shall not exceed 0.003" (0.076 mm) per side or 0.006" (0.152 mm) more than dimension "B."

‡ Dimensions "D" and "E" do not include mold flash or protrusions. Mold flash or protrusions shall not exceed 0.010" (0.254 mm) per side or 0.020" (0.508 mm) more than dimensions "D" or "E."

APPENDIX A: FEATURE IMPROVEMENTS - FROM PIC16C5X TO PIC16C84

The following is the list of feature improvements over the PIC16C5X microcontroller family:

1. Instruction word length is increased to 14 bits. This allows larger page sizes both in program memory (2K now as opposed to 512 before) and the register file (128 bytes now versus 32 bytes before).
2. A PC latch register (PCLATH) is added to handle program memory paging. PA2, PA1 and PA0 bits are removed from the status register and placed in the option register.
3. Data memory paging is redefined slightly. The STATUS register is modified.
4. Four new instructions have been added: RETURN, RETFIE, ADDLW, and SUBLW. Two instructions, TRIS and OPTION, are being phased out although they are kept for compatibility with PIC16C5X.
5. OPTION and TRIS registers are made addressable.
6. Interrupt capability is added. Interrupt vector is at 0004h.
7. Stack size is increased to 8 deep.
8. Reset vector is changed to 0000h.
9. Reset of all registers is revisited. Five different reset (and wake-up) types are recognized. Registers are reset differently.
10. Wake up from SLEEP through interrupt is added.
11. Two separate timers, the Oscillator Start-up Timer (OST) and Power-up Timer (PWRT), are included for more reliable power-up. These timers are invoked selectively to avoid unnecessary delays on power-up and wake-up.
12. PORTB has weak pull-ups and interrupt on change features.
13. T0CKI pin is also a port pin (RA4/T0CKI).
14. FSR is a full 8-bit register.
15. "In system programming" is made possible. The user can program PIC16CXX devices using only five pins: VDD, VSS, VPP, RB6 (clock) and RB7 (data in/out).

APPENDIX B: CODE COMPATIBILITY - FROM PIC16C5X TO PIC16C84

To convert code written for PIC16C5X to PIC16C84, the user should take the following steps:

1. Remove any program memory page select operations (PA2, PA1, PA0 bits) for CALL, GOTO.
2. Revisit any computed jump operations (write to PC or add to PC, etc.) to make sure page bits are set properly under the new scheme.
3. Eliminate any data memory page switching. Redefine data variables for reallocation.
4. Verify all writes to STATUS, OPTION, and FSR registers since these have changed.
5. Change reset vector to 0000h.

PIC16C84

APPENDIX C: WHAT'S NEW IN THIS DATA SHEET

No new information has been added to this data sheet.

For information on upgrade devices from the PIC16C84, please refer to the PIC16F8X data sheet.

APPENDIX D: WHAT'S CHANGED IN THIS DATA SHEET

Here's what's changed in this data sheet:

1. Some sections have been rearranged for clarity and consistency.
2. Errata information has been included.

APPENDIX E: CONVERSION CONSIDERATIONS - PIC16C84 TO PIC16F83/F84 AND PIC16CR83/CR84

Considerations for converting from the PIC16C84 to the PIC16F84 are listed in the table below. These considerations apply to converting from the PIC16C84 to the PIC16F83 (same as PIC16F84 except for program

and data RAM memory sizes) and the PIC16CR84 and PIC16CR83 (ROM versions of Flash devices). Development Systems support is available for all of the PIC16X8X devices.

Difference	PIC16C84	PIC16F84
The polarity of the PWRTE bit has been reversed. Ensure that the programmer has this bit correctly set before programming.	PWRTE	$\overline{\text{PWRTE}}$
The PIC16F84 (and PIC16CR84) have larger RAM sizes. Ensure that this does not cause an issue with your program.	RAM = 36 bytes	RAM = 68 bytes
The $\overline{\text{MCLR}}$ pin now has an on-chip filter. The input signal on the $\overline{\text{MCLR}}$ pin will require a longer low pulse to generate an interrupt.	$\overline{\text{MCLR}}$ pulse width (low) = 350ns; $2.0\text{V} \leq V_{\text{DD}} \leq 3.0\text{V}$ = 150ns; $3.0\text{V} \leq V_{\text{DD}} \leq 6.0\text{V}$	$\overline{\text{MCLR}}$ pulse width (low) = 1000ns; $2.0\text{V} \leq V_{\text{DD}} \leq 6.0\text{V}$
Some electrical specifications have been improved (see IPD example). Compare the electrical specifications of the two devices to ensure that this will not cause a compatibility issue.	IPD (typ @ 2V) = 26 μA IPD (max @ 4V, WDT disabled) =100 μA (PIC16C84) =100 μA (PIC16LC84)	IPD (typ @ 2V) < 1 μA IPD (max @ 4V, WDT disabled) =14 μA (PIC16F84) =7 μA (PIC16LF84)
PORTA and crystal oscillator values less than 500kHz	For crystal oscillator configurations operating below 500kHz, the device may generate a spurious internal Q-clock when PORTA<0> switches state.	N/A
RB0/INT pin	TTL	TTL/ST* (* This buffer is a Schmitt Trigger input when configured as the external interrupt.)
EEADR<7:6> and IDD	It is recommended that the EEADR<7:6> bits be cleared. When either of these bits is set, the maximum IDD for the device is higher than when both are cleared.	N/A
Code Protect	1 CP bit	9 CP bits
Recommended value of REXT for RC oscillator circuits	REXT = 3k Ω - 100k Ω	REXT = 5k Ω - 100k Ω
GIE bit unintentional enable	If an interrupt occurs while the Global Interrupt Enable (GIE) bit is being cleared, the GIE bit may unintentionally be re-enabled by the user's Interrupt Service Routine (the RETFIE instruction).	N/A

PIC16C84

NOTES:

INDEX

A

Absolute Maximum Ratings	71
ALU	7
Architectural Overview	7
Assembler	
MPASM Assembler	68

B

Block Diagram	
Interrupt Logic	45
On-Chip Reset Circuit	38
RA3:RA0 and RA5 Port Pins	19
RA4 Pin	19
RB3:RB0 Port Pins	21
RB7:RB4 Port Pins	21
TMR0/WDT Prescaler	28
Watchdog Timer	47
Brown-out Protection Circuit	43

C

Carry	7
CLKIN	9
CLKOUT	9
Code Protection	35, 49
Compatibility, upward	3
Computed GOTO	17
Configuration Bits	35

D

DC Characteristics	73, 74, 75, 76
Development Support	67
Development Tools	67
Digit Carry	7

E

External Power-on Reset Circuit	40
---------------------------------------	----

F

Family of Devices	
PIC16C8X	4
FSR	18, 39
Fuzzy Logic Dev. System (<i>fuzzyTECH</i> ®-MP)	69

G

GIE	44
-----------	----

I

I/O Ports	19
I/O Programming Considerations	23
ICEPIC Low-Cost PIC16CXXX In-Circuit Emulator	67
In-Circuit Serial Programming	35, 49
INDF	39
Instruction Format	51
Instruction Set	
ADDLW	53
ADDWF	53
ANDLW	53
ANDWF	53
BCF	54
BSF	54
BTFSC	54
BTFSS	55
CALL	55
CLRF	56
CLRW	56

CLRWDT	56
COMF	57
DECF	57
DECFSZ	57
GOTO	58
INCF	58
INCFSZ	59
IORLW	59
IORWF	60
MOVF	60
MOVLW	60
MOVWF	60
NOP	61
OPTION	61
RETFIE	61
RETLW	62
RETURN	62
RLF	63
RRF	63
SLEEP	64
SUBLW	64
SUBWF	65
SWAPF	65
TRIS	65
XORLW	66
XORWF	66
Section	51
Summary Table	52

INT Interrupt	46
INTCON	16, 39, 44, 46
INTEDG	46
Interrupts	
Flag	44
Interrupt on Change Feature	21
Interrupts	35, 44

K

KeeLoq® Evaluation and Programming Tools	69
--	----

L

Loading of PC	17
---------------------	----

M

$\overline{\text{MCLR}}$	9, 38, 39
Memory Organization	
Data Memory	12
Memory Organization	11
Program Memory	11
MP-DriveWay™ - Application Code Generator	69
MPLAB C	69
MPLAB Integrated Development Environment Software ...	68

O

OPCODE	51
OPTION_REG	15, 39, 46
OSC selection	35
OSC1	9
OSC2	9
Oscillator	
HS	36, 43
LP	36, 43
RC	36, 37
XT	36, 43
Oscillator Configurations	36

P

Paging, Program Memory	17
------------------------------	----

PIC16C84

PCL	17, 39
PCLATH	17, 39
\overline{PD}	14, 38, 43
PICDEM-1 Low-Cost PICmicro Demo Board	68
PICDEM-2 Low-Cost PIC16CXX Demo Board	68
PICDEM-3 Low-Cost PIC16CXXX Demo Board	68
PICMASTER® In-Circuit Emulator	67
PICSTART® Plus Entry Level Development System	67
Pinout Descriptions	9
POR	40
Oscillator Start-up Timer (OST)	35, 40
Power-on Reset (POR)	35, 39, 40
Power-up Timer (PWRT)	35, 40
Time-out Sequence	43
Time-out Sequence on Power-up	41
\overline{TO}	14, 38, 43
Port RB Interrupt	46
PORTA	9, 19, 39
PORTB	9, 21, 39
Power-down Mode (SLEEP)	48
Prescaler	27
PRO MATE® II Universal Programmer	67
Product Identification System	107

R

RBIF bit	21, 46
RC Oscillator	43
Read-Modify-Write	23
Register File	12
Reset	35, 38
Reset on Brown-Out	43

S

Saving W Register and STATUS in RAM	46
SEEVAL® Evaluation and Programming System	69
SLEEP	35, 38, 48
Software Simulator (MPLAB-SIM)	69
Special Features of the CPU	35
Special Function Registers	12
Stack	17
Overflows	17
Underflows	17
STATUS	7, 14, 39

T

time-out	39
Timer0	
Switching Prescaler Assignment	29
TOIF	46
Timer0 Module	25
TMR0 Interrupt	46
TMR0 with External Clock	27
Timing Diagrams	
Time-out Sequence	41
Timing Diagrams and Specifications	78
TRISA	19
TRISB	21, 39

W

W	39
Wake-up from SLEEP	39, 48
Watchdog Timer (WDT)	35, 38, 39, 47
WDT	39
Period	47
Programming Considerations	47
Time-out	39

Z

Zero bit	7
----------------	---

ON-LINE SUPPORT

Microchip provides two methods of on-line support. These are the Microchip BBS and the Microchip World Wide Web (WWW) site.

Use Microchip's Bulletin Board Service (BBS) to get current information and help about Microchip products. Microchip provides the BBS communication channel for you to use in extending your technical staff with microcontroller and memory experts.

To provide you with the most responsive service possible, the Microchip systems team monitors the BBS, posts the latest component data and software tool updates, provides technical help and embedded systems insights, and discusses how Microchip products provide project solutions.

The web site, like the BBS, is used by Microchip as a means to make files and information easily available to customers. To view the site, the user must have access to the Internet and a web browser, such as Netscape or Microsoft Explorer. Files are also available for FTP download from our FTP site.

Connecting to the Microchip Internet Web Site

The Microchip web site is available by using your favorite Internet browser to attach to:

www.microchip.com

The file transfer site is available by using an FTP service to connect to:

[ftp.mchip.com/biz/mchip](ftp://mchip.com/biz/mchip)

The web site and file transfer site provide a variety of services. Users may download files for the latest Development Tools, Data Sheets, Application Notes, User's Guides, Articles and Sample Programs. A variety of Microchip specific business information is also available, including listings of Microchip sales offices, distributors and factory representatives. Other data available for consideration is:

- Latest Microchip Press Releases
- Technical Support Section with Frequently Asked Questions
- Design Tips
- Device Errata
- Job Postings
- Microchip Consultant Program Member Listing
- Links to other useful web sites related to Microchip Products

Connecting to the Microchip BBS

Connect worldwide to the Microchip BBS using either the Internet or the CompuServe® communications network.

Internet:

You can telnet or ftp to the Microchip BBS at the address:

[mchipbbs.microchip.com](telnet://mchipbbs.microchip.com)

CompuServe Communications Network:

When using the BBS via the Compuserve Network, in most cases, a local call is your only expense. The Microchip BBS connection does not use CompuServe membership services, therefore you do not need CompuServe membership to join Microchip's BBS. There is no charge for connecting to the Microchip BBS.

The procedure to connect will vary slightly from country to country. Please check with your local CompuServe agent for details if you have a problem. CompuServe service allow multiple users various baud rates depending on the local point of access.

The following connect procedure applies in most locations.

1. Set your modem to 8-bit, No parity, and One stop (8N1). This is not the normal CompuServe setting which is 7E1.
2. Dial your local CompuServe access number.
3. Depress the <Enter> key and a garbage string will appear because CompuServe is expecting a 7E1 setting.
4. Type +, depress the <Enter> key and "Host Name:" will appear.
5. Type MCHIPBBS, depress the <Enter> key and you will be connected to the Microchip BBS.

In the United States, to find the CompuServe phone number closest to you, set your modem to 7E1 and dial (800) 848-4480 for 300-2400 baud or (800) 331-7166 for 9600-14400 baud connection. After the system responds with "Host Name:", type NETWORK, depress the <Enter> key and follow CompuServe's directions.

For voice information (or calling from overseas), you may call (614) 723-1550 for your local CompuServe number.

Microchip regularly uses the Microchip BBS to distribute technical information, application notes, source code, errata sheets, bug reports, and interim patches for Microchip systems software products. For each SIG, a moderator monitors, scans, and approves or disapproves files submitted to the SIG. No executable files are accepted from the user community in general to limit the spread of computer viruses.

Systems Information and Upgrade Hot Line

The Systems Information and Upgrade Line provides system users a listing of the latest versions of all of Microchip's development systems software products. Plus, this line provides information on how customers can receive any currently available upgrade kits. The Hot Line Numbers are:

- 1-800-755-2345 for U.S. and most of Canada, and
- 1-602-786-7302 for the rest of the world.

Trademarks: The Microchip name, logo, PIC, PICSTART, PICMASTER, PRO MATE and are registered trademarks of Microchip Technology Incorporated in the U.S.A. and other countries. PICmicro, FlexROM, MPLAB, and fuzzy-LAB, are trademarks and SQTP is a service mark of Microchip in the U.S.A.

fuzzyTECH is a registered trademark of Inform Software Corporation. IBM, IBM PC-AT are registered trademarks of International Business Machines Corp. Pentium is a trademark of Intel Corporation. Windows is a trademark and MS-DOS, Microsoft Windows are registered trademarks of Microsoft Corporation. CompuServe is a registered trademark of CompuServe Incorporated.

All other trademarks mentioned herein are the property of their respective companies.

PIC16C84 PRODUCT IDENTIFICATION SYSTEM

To order or obtain information, e.g., on pricing or delivery, refer to the factory or the listed sales office.

<u>PART NO.</u>	<u>-XX</u>	<u>X</u>	<u>/XX</u>	<u>XXX</u>	
Device	Frequency Range	Temperature Range	Package	Pattern	Examples:
Device	PIC16C84 ⁽²⁾ , PIC16C84T ⁽³⁾ PIC16LC84 ⁽²⁾ , PIC16LC84T ⁽³⁾				a) PIC16C84 -04/P 301 = Commercial temp., PDIP package, 4MHz, normal VDD limits, QTP pattern #301.
Frequency Range	04 = 4 MHz 10 = 10 MHz				b) PIC16LC84 - 04I/SO = Industrial temp., SOIC package, 200kHz, Extended VDD limits.
Temperature Range	b ⁽¹⁾ = 0°C to +70°C (Commercial) I = -40°C to +85°C (Industrial)				
Package	P = PDIP SO = SOIC (Gull Wing, 300 mil body)				
Pattern	3-digit Pattern Code for QTP, ROM (blank otherwise)				
					Note 1: b = blank 2: C = Standard VDD range LC = Extended VDD range 3: T = in tape and reel - SOIC, SSOP packages only.

SALES AND SUPPORT

Data Sheets

Products supported by a preliminary Data Sheet may have an errata sheet describing minor operational differences and recommended workarounds. To determine if an errata sheet exists for a particular device, please contact one of the following:

1. Your local Microchip sales office (see last page)
 2. The Microchip Corporate Literature Center U.S. FAX: (602) 786-7277
 3. The Microchip's Bulletin Board, via your local CompuServe number (CompuServe membership NOT required).
- Please specify which device, revision of silicon and Data Sheet (include Literature #) you are using.

Development Tools

For the latest version information and upgrade kits for Microchip Development Tools, please call 1-800-755-2345 or 1-602-786-7302. The latest version of Development Tools software can be downloaded from either our Bulletin Board or Worldwide Web Site. (Information on how to connect to our BBS or WWW site can be found in the On-Line Support section of this data sheet.)



MICROCHIP

WORLDWIDE SALES AND SERVICE

AMERICAS

Corporate Office

Microchip Technology Inc.
2355 West Chandler Blvd.
Chandler, AZ 85224-6199
Tel: 602-786-7200 Fax: 602-786-7277
Technical Support: 602 786-7627
Web: <http://www.microchip.com>

Atlanta

Microchip Technology Inc.
500 Sugar Mill Road, Suite 200B
Atlanta, GA 30350
Tel: 770-640-0034 Fax: 770-640-0307

Boston

Microchip Technology Inc.
5 Mount Royal Avenue
Marlborough, MA 01752
Tel: 508-480-9990 Fax: 508-480-8575

Chicago

Microchip Technology Inc.
333 Pierce Road, Suite 180
Itasca, IL 60143
Tel: 630-285-0071 Fax: 630-285-0075

Dallas

Microchip Technology Inc.
14651 Dallas Parkway, Suite 816
Dallas, TX 75240-8809
Tel: 972-991-7177 Fax: 972-991-8588

Dayton

Microchip Technology Inc.
Two Prestige Place, Suite 150
Miamisburg, OH 45342
Tel: 937-291-1654 Fax: 937-291-9175

Los Angeles

Microchip Technology Inc.
18201 Von Karman, Suite 1090
Irvine, CA 92612
Tel: 714-263-1888 Fax: 714-263-1338

New York

Microchip Technology Inc.
150 Motor Parkway, Suite 202
Hauppauge, NY 11788
Tel: 516-273-5305 Fax: 516-273-5335

San Jose

Microchip Technology Inc.
2107 North First Street, Suite 590
San Jose, CA 95131
Tel: 408-436-7950 Fax: 408-436-7955

Toronto

Microchip Technology Inc.
5925 Airport Road, Suite 200
Mississauga, Ontario L4V 1W1, Canada
Tel: 905-405-6279 Fax: 905-405-6253

ASIA/PACIFIC

Hong Kong

Microchip Asia Pacific
RM 3801B, Tower Two
Metroplaza
223 Hing Fong Road
Kwai Fong, N.T., Hong Kong
Tel: 852-2-401-1200 Fax: 852-2-401-3431

India

Microchip Technology Inc.
India Liaison Office
No. 6, Legacy, Convent Road
Bangalore 560 025, India
Tel: 91-80-229-0061 Fax: 91-80-229-0062

Japan

Microchip Technology Intl. Inc.
Benex S-1 6F
3-18-20, Shinyokohama
Kohoku-Ku, Yokohama-shi
Kanagawa 222 Japan
Tel: 81-45-471-6166 Fax: 81-45-471-6122

Korea

Microchip Technology Korea
168-1, Youngbo Bldg. 3 Floor
Samsung-Dong, Kangnam-Ku
Seoul, Korea
Tel: 82-2-554-7200 Fax: 82-2-558-5934

Shanghai

Microchip Technology
RM 406 Shanghai Golden Bridge Bldg.
2077 Yan'an Road West, Hong Qiao District
Shanghai, PRC 200335
Tel: 86-21-6275-5700
Fax: 86 21-6275-5060

Singapore

Microchip Technology Taiwan
Singapore Branch
200 Middle Road
#07-02 Prime Centre
Singapore 188980
Tel: 65-334-8870 Fax: 65-334-8850

ASIA/PACIFIC (CONTINUED)

Taiwan, R.O.C

Microchip Technology Taiwan
10F-1C 207
Tung Hua North Road
Taipei, Taiwan, ROC
Tel: 886-2-2717-7175 Fax: 886-2-2545-0139

EUROPE

United Kingdom

Arizona Microchip Technology Ltd.
505 Eskdale Road
Winnersh Triangle
Wokingham
Berkshire, England RG41 5TU
Tel: 44-1189-21-5858 Fax: 44-1189-21-5835

France

Arizona Microchip Technology SARL
Zone Industrielle de la Bonde
2 Rue du Buisson aux Fraises
91300 Massy, France
Tel: 33-1-69-53-63-20 Fax: 33-1-69-30-90-79

Germany

Arizona Microchip Technology GmbH
Gustav-Heinemann-Ring 125
D-81739 München, Germany
Tel: 49-89-627-144 0 Fax: 49-89-627-144-44

Italy

Arizona Microchip Technology SRL
Centro Direzionale Colleoni
Palazzo Taurus 1 V. Le Colleone 1
20041 Agrate Brianza
Milan, Italy
Tel: 39-39-6899939 Fax: 39-39-6899883

1/13/98



Microchip received ISO 9001 Quality System certification for its worldwide headquarters, design, and wafer fabrication facilities in January, 1997. Our field-programmable PICmicro™ 8-bit MCUs, Serial EEPROMs, related specialty memory products and development systems conform to the stringent quality standards of the International Standard Organization (ISO).

All rights reserved. © 1998, Microchip Technology Incorporated, USA. 1/98 Printed on recycled paper.

Information contained in this publication regarding device applications and the like is intended for suggestion only and may be superseded by updates. No representation or warranty is given and no liability is assumed by Microchip Technology Incorporated with respect to the accuracy or use of such information, or infringement of patents or other intellectual property rights arising from such use or otherwise. Use of Microchip's products as critical components in life support systems is not authorized except with express written approval by Microchip. No licenses are conveyed, implicitly or otherwise, under any intellectual property rights. The Microchip logo and name are registered trademarks of Microchip Technology Inc. in the U.S.A. and other countries. All rights reserved. All other trademarks mentioned herein are the property of their respective companies.